

CN0055 & CN0055B

DC to DC
NEGATIVE RESISTANCE
SPEED CONTROL



This manual contains information for installing and operating the following Centent Company products:

- CN0055 Negative Resistance Speed Control
- CN0055B Negative Resistance Speed Control

Centent and the Centent Company logo are trademarks of Centent Company. Other trademarks, tradenames, and service marks owned or registered by any other company and used in this manual are the property of their respective companies.

Copyright © 2011 Centent Company
3879 South Main Street
Santa Ana, CA 97207
All Rights Reserved

GENERAL DESCRIPTION

The CN0055 and CN0055B are DC to DC variable speed controls for small permanent magnet (PM) motors. Very accurate motor speed regulation is possible by merely turning the speed potentiometer knob.

The control is designed for motors rated from 6-32 VDC. Power supply voltage should match the motor's rated voltage. **Operation above rated motor voltage may result in damage to the motor.**

The control operates on the Negative Resistance Principle. This states that if a PM motor's armature resistance is cancelled by an equal negative resistance, the motor's speed will not change with varying load.

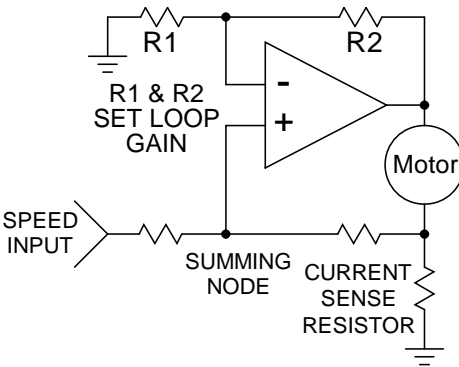

The control senses the motor current, which is directly proportional to motor torque, generates a proportional voltage (amplified by a constant set by the Regulation trimmer) and sums it with the Speed Input voltage. When properly trimmed, this compensation voltage cancels any drop in speed due to motor load.

The CN0055 and CN0055B are encapsulated in a heat conductive epoxy and encased in an anodized aluminum cover. This provides a rugged and compact package that resists abuse and contamination.

The CN0055B features an additional trimpot, the Offset Trim, located next to the Regulation Trimpot. See ADJUSTMENT (page 2), steps F-H for details on setting this trimpot.

INSTALLATION

Mounting holes for #4 machine screws are provided in each corner of the bottom plate. When operating the CN0055 or CN0055B at high power levels additional heat sinking is required to keep the control within the specified operating temperature range.

A 10 position terminal strip located on the front edge of the control provides the connections for the motor, speed potentiometer and power supply. No terminals or connectors are required on the wiring to the control. The recommended wire size is 16-22 gauge.

MOTOR OUTPUTS

TERMINALS 8 & 10

The positive motor lead goes to terminal 8 and the negative motor lead goes to terminal 10. The maximum (motor) current is 5 amps for the CN0055 and 3 amps for the CN0055B. **If the motor leads are reversed to change motor direction, the correct switch type (break before make) must be used.**

POTENTIOMETER REFERENCE VOLTAGE

TERMINAL 9

Terminal 9 is the voltage reference output for the Speed Pot. Attach one end of a 5-10K ohm potentiometer to this terminal. Use a 'linear taper' potentiometer. If a control voltage input is used instead of a potentiometer, this terminal is not used.

+6 to 32 VDC

TERMINALS 6 & 7

The positive power supply input is connected to terminal 7. Pin 6 is connected internally to Pin 7. The power supply input voltage range is 6 to 32 VDC.

SPEED INPUT

TERMINAL 5

Terminal 5 is the speed control input to the control. Connect this terminal to the wiper of the Speed Potentiometer. If a control voltage is used instead of a potentiometer, the range is 0-10 VDC for the CN0055 and 0-5 VDC for the CN0055B.

GROUND

TERMINALS 1,2,3,4

Terminals 1-4 are ground. Use terminal 1 for the power supply ground. Connect terminal 3 to the negative terminal of the Speed potentiometer if one is used.

ADJUSTMENT

The procedure for setting up the CN0055 or CN0055B is as follows:

- a) Set the motor speed to 5-10% of maximum speed. If the motor oscillates turn the Regulation trimmer counter-clockwise until the motor runs smoothly.
- b) Apply a load to the motor and observe whether the speed increases or decreases.
- c) Remove the load.
- d) If the speed increased under load, turn the Regulation trimmer counter-clockwise. If the speed decreased under load, turn the Regulation trimmer clockwise
- e) Repeat steps B through D until there is no observable change in speed when the load is applied and then removed.

This completes the set-up of the CN0055. For the CN0055B the following procedure adjusts the zero speed offset.

- f) Set the speed control voltage on terminal 5 to zero volts.
- g) If the motor is running then proceed to step h. If the motor is stopped, turn the Offset trimmer clockwise until the motor just begins to move.
- h) Turn the Offset trimmer clockwise until the motor just stops.

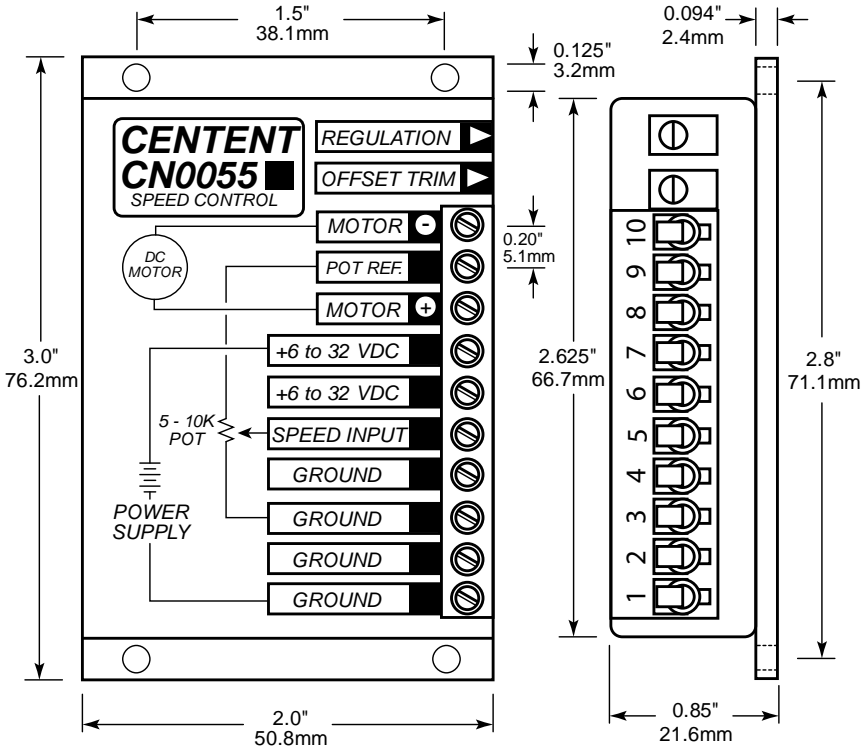

CN0055 & CN0055B

SPECIFICATIONS

ELECTRICAL	MIN.	MAX.	UNIT
Supply Voltage	6	32	VDC
Supply Current			
CN0055		6	A
CN0055B		3.5	A
Continuous Run Current			
CN0055		5	A
CN0055B		3	A
Speed Input Voltage			
CN0055	0	10	V
CN0055B	0	5	V
Speed Regulation	5	5	%
Speed Range	50:1		
Potentiometer Impedance	5K	10K	ohms
ENVIRONMENTAL	MIN.	MAX.	UNIT
Operating Temperature	-40	+75	°C
Weight	165	175	grams
Terminal Screw Torque		4.5	lb/in