

CN0122

DUAL INPUT MOTOR DRIVE

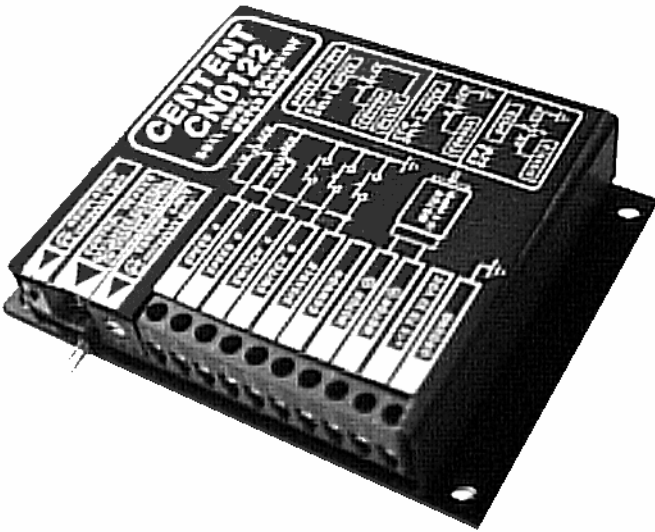

3879 SOUTH MAIN STREET 714-979-6491
SANTA ANA, CALIFORNIA 92707-5710 U.S.A.

This manual contains information for installing and operating the following Centent Company product:

CN0122 Dual Input Motor Drive

Centent and the Centent Company logo are trademarks of Centent Company. Other trademarks, tradenames, and service marks owned or registered by any other company and used in this manual are the property of their respective companies.

Copyright © 2011 Centent Company
3879 South Main Street
Santa Ana, CA 97207
All Rights Reserved

GENERAL DESCRIPTION

The CN0122 is an H-Bridge servo amplifier DC motor control designed for bi-directional operation of permanent magnet motors. It features two separate speed inputs for controlling the speed or torque of the motor. These inputs are activated alternately, by momentarily shorting selector switch inputs to ground. Shorting Switch A to ground selects the Speed A input; shorting Switch B selects the Speed B input. The CN0122 is well suited for mechanical oscillator applications due to this alternating input feature. The control is also ideal for position servo or velocity servo applications requiring only one speed input.

The Control Header sets the CN0122 as a speed control or a torque control. Maximum motor current is five amps and maximum supply voltage is 32 volts DC. When adequately heat sunk, the CN0122 can dissipate 150 watts of power. Full output current is available over the full range of power supply voltage.

COMPONENT LOCATION

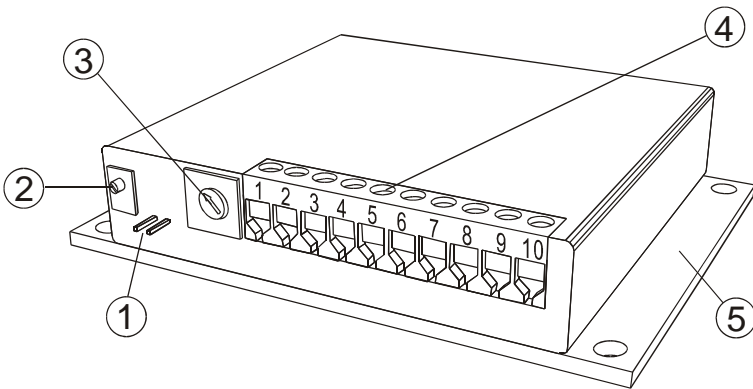

- (1) CONTROL HEADER
- (2) REGULATION TRIMPOT
- (3) TORQUE LIMIT TRIMPOT
- (4) TERMINAL STRIP CONNECTOR
- (5) MOUNTING PLATE

(1) CONTROL HEADER

This two pin header sets the operating mode of the CN0122. Speed Control Mode is selected with no pins connected. Torque Control Mode is selected by installing the provided jumper across the header pins.

SPEED CONTROL MODE:

The CN0122 drives the motor at a speed proportional to the Speed input. The control senses motor load and adjusts the motor voltage to keep speed independent of load. The amount of adjustment needed is set by the Regulation Trimpot and depends on the motor used. The Torque Limit Trimpot sets the current or torque limit and is adjustable from zero to five amps.

VELOCITY CONTROL:

By turning the Regulation Trimpot the maximum counter-clockwise position (in Speed Control Mode, with no jumper bar on the Control Header) the CN0122 functions as a Velocity Control. The control drives the motor with a voltage proportional to the Speed Input. The motor will slow down under load.

TORQUE CONTROL MODE:

The CN0122 drives the motor with a current or torque proportional to the Speed input. The Torque Limit Trimpot sets the current or torque limit and is adjustable from zero to five amps. The Regulation Trimpot must be turned to the full counter-clockwise position for operation in the Torque Control Mode.

(2) REGULATION TRIMPOT

In Speed Control Mode the Regulation Trimpot is used to keep motor speed independent of the torque load. The following procedure is used to adjust the Regulation Trimpot in Speed Control Mode:

- 1) Set the Torque Limit Trimpot to the desired torque limit.
- 2) Turn the Regulation Trimpot counter-clockwise 10 turns.
- 3) Set the motor speed to 5-10% of maximum speed.
- 4) Apply a load to the motor and observe the speed.
- 5) If speed decreases under load, turn the trimpot clockwise and repeat step (4).
If speed increases under load, turn the trimpot counter-clockwise 1/4 turn.

In Torque Control Mode the Regulation Trimpot must be turned to the full counter-clockwise position.

(3) TORQUE LIMIT TRIMPOT

The Torque Limit Trimpot sets the current or torque limit. It is adjustable from zero to five amps. Turn the trimpot clockwise to increase motor torque.

(4) TERMINAL STRIP CONNECTOR

No terminals or connectors are required on the wiring to the CN0122. The recommended wire size is 16-22 gauge. The pin assignments and functions are described in the following sections.

SPEED INPUTS

TERMINALS 1 & 2

These are the command inputs to the CN0122. Labeled Speed A and Speed B, only one is selected at a time, by using the Switch A and Switch B inputs. If external potentiometers are used, the Speed Inputs are connected to the wipers. The potentiometer's minimum resistance is 5K Ω , maximum resistance is 50K Ω . Do not use audio taper potentiometers.

CW & CCW OPERATION:

For bi-directional operation connect one end of the potentiometer to the Disable terminal and the other end to the Ground terminal. The wiper of the trimpot connects to the Speed A or Speed B input. Switch A and Switch B inputs select their respective potentiometer inputs.

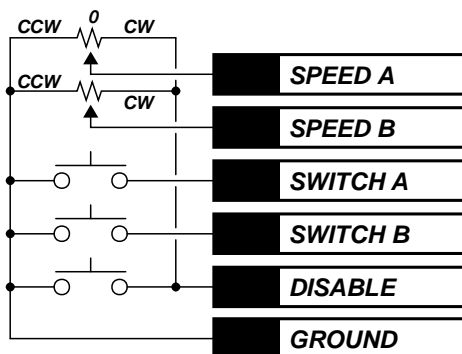

CW ONLY OPERATION:

Connect one end of the potentiometer to the Disable terminal and the other end to the Common terminal. The wiper of the trimpot connects to the Speed A or Speed B input. Switch A and Switch B inputs select their respective potentiometer inputs.

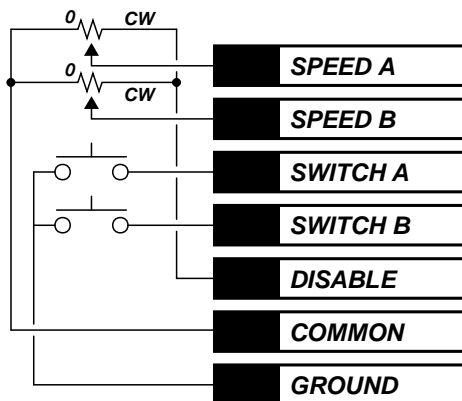

CCW ONLY OPERATION:

Connect one end of the potentiometer to the Common terminal and the other end of the potentiometer to the Ground terminal. The wiper of the trimpot connects to the Speed A or Speed B input. Switch A and Switch B inputs select their respective potentiometer inputs.

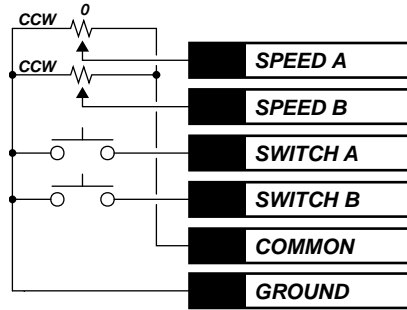

When power is first applied the Speed A input is selected. Resetting the power supply will return the CN0122 to Speed A input selection.

The Speed Inputs (A or B) may also be driven by a plus or minus 10 volt signal as shown.

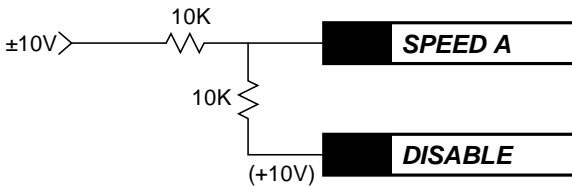

SWITCH INPUTS

TERMINALS 3 & 4

The Switch A and Switch B inputs work much like the station select buttons on a car radio. Momentarily shorting Switch A to ground will select Speed A as the active speed input. Momentarily shorting Switch B to ground will select Speed B as the active speed input.

When power is applied to the CN0122 Switch A is the active input. If only one Speed Input is required, the Switch inputs may be left unconnected and Speed A used for input.

DISABLE

TERMINAL 5

Shorting the Disable terminal to ground removes all power from the motor. This allows the motor to “free wheel”. The Disable Terminal is also connected to one end of the speed potentiometers in “CCW & CW” and “CW Only” operation. It is not connected to the speed potentiometers for “CCW Only” operation. Terminal 5 is the +10 volt (@ 10mA) power supply for the Speed Potentiometers.

COMMON

TERMINAL 6

This terminal is connected to the speed potentiometers in “CW Only” and “CCW Only” operation. It is not used for “CCW & CW” operation. Terminal 6 is the +5 volt (@ 50mA) power supply for the Speed Potentiometers.

MOTOR OUTPUTS

TERMINALS 7 & 8

The positive motor lead goes to terminal 7 and the negative motor lead goes to terminal 8. The maximum available current is five amps. The output stages use 15 amp @ 80 volt power transistors. The output is diode clamped to ground and the positive supply voltage.

POWER SUPPLY INPUTS

TERMINALS 9 & 10

The power supply is connected across Pin 9 and Pin 10. Pin 9 is positive and Pin 10 is the supply ground. Reversing the power supply leads to the CN0122 will result in the destruction of the drive; so be careful and check the wiring before powering up the circuit.

A regulated supply is recommended but is not necessary. The power supply voltage can range from 15 VDC to 32 VDC. Do not exceed the maximum rated voltage. The current rating of the supply must be at least equal to the maximum motor current.

(5) MOUNTING PLATE

The CN0122 is a linear amplifier. As a consequence it may dissipate considerable heat while running large motors at low speed under heavy load. This heat may cause damaging temperatures in the CN0122. For this reason it is extremely important to properly heat sink the drive.

Mount the CN0122 on a finned aluminum heat sink using thermal compound between the CN0122 and the heat sink. If needed, use a fan to force air over the heat sink. Monitor the case temperature of the CN0122 under the worst case motor load conditions. Do not let the case temperature exceed 70°C (158°F).

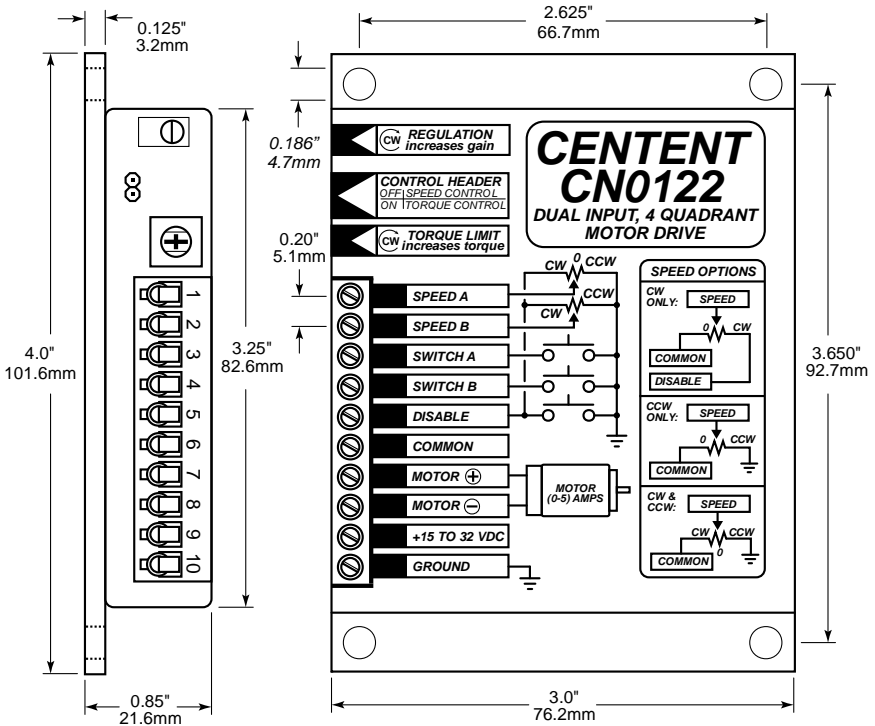

SPECIFICATIONS

ELECTRICAL	MIN.	MAX.	UNIT
Power Supply Voltage	15	32	VDC
Power Supply Current*	--	30	mA
Maximum Load Current	-5	+5	A
Voltage Gain	25.6	28.3	%
Frequency Response	DC	20	kHz
Input Impedance	1M	--	ohms
Input Potentiometer	5K	50K	ohms
Disable Current (Terminal 5, 10V)	--	10	mA
Common Current (Terminal 6, 5V)	--	50	mA
* with no motor connected			
ENVIRONMENTAL	MIN.	MAX.	UNIT
Operating Temperature	-40	+70	°C
	-40	+158	°F
Weight	10.6	14.1	ounce
Terminal Screw Torque	300	400	gram
		4.5	lb/in
DIMENSIONS			UNIT
Size (L x W x H)	4.0 x 3.0 x 0.85		inch
	102 x 76 x 22		mm.
Mounting hole centers	3.650 x 2.625		inch
	93 x 67		mm.