

CN0172

PRESET INDEXER

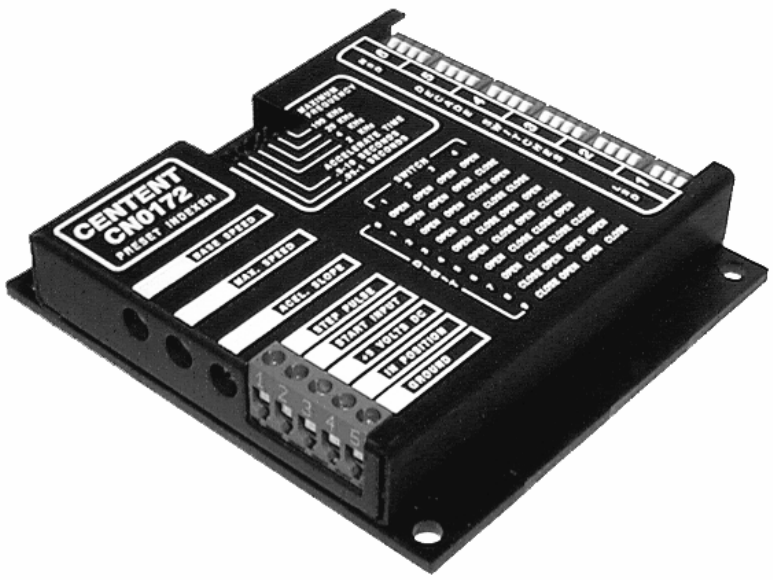

CENTENT
O M P A N Y

3879 SOUTH MAIN STREET 714-979-6491
SANTA ANA, CALIFORNIA 92707-5710 U.S.A.

This manual contains information for installing and operating the following Centent Company product:

CN0172 Preset Indexer

Centent and the Centent Company logo are trademarks of Centent Company. Other trademarks, tradenames, and service marks owned or registered by any other company and used in this manual are the property of their respective companies.

Copyright © 2011 Centent Company
3879 South Main Street
Santa Ana, CA 97207
All Rights Reserved

GENERAL DESCRIPTION

The CN0172 is a low cost preset indexer. The control provides a step pulse output for a step motor drive. It is intended for applications requiring a fixed number of steps per indexing cycle. Base speed, maximum speed and acceleration are set by trimming potentiometers. The number of steps to be taken is set by DIP switches. The indexing cycle is initiated by a signal from the user. An output from the CN0172 indicates when the cycle has completed. The linearity of trimpot adjustment is excellent throughout the operating range. Four maximum speed ranges and three acceleration ranges facilitate easy adjustment. The CN0172 operates on a +5 VDC power supply and draws a maximum of 100mA.

BASE SPEED TRIMPOT

This controls the speed from which acceleration begins for an index cycle. The base speed is adjustable from zero to full scale, though it is generally set to a value of around 1 to 3 revolutions (200-600 full steps) per second. Clockwise rotation of the Base Speed Trimpot increases base speed.

MAXIMUM SPEED TRIMPOT

This controls the speed to which the motor accelerates during an index cycle. The speed range and trimpot rotation are the same as for the Base Speed Trimpot. If the maximum speed is set to a value less than the base speed, the motor will run at the base speed, with no acceleration during the index cycle.

Note: Do not set both speed trimpots to zero. The CN0172 will not be able to complete an index cycle at zero speed. To run at the lowest possible speed use the following procedure:

1. Set both speed trimpots to zero.
2. Set the decade switches for smallest possible move (Digit 1 – Switch 4 = ON; all reset OFF)
3. Initiate start cycle (Start Input → ground momentarily)
4. Turn Base Speed Trimpot CW SLOWLY until In Position output goes active (high).

ACCELERATION SLOPE TRIMPOT

This controls the rate of acceleration from base speed to maximum speed during an index cycle. The deceleration slope (at the end of the index cycle) is a mirror image of the acceleration slope. The Acceleration Slope Trimpot is adjustable over a 20 to 1 range. Clockwise rotation of the Acceleration Slope Trimpot decreases the rate of acceleration.

RANGE OPTION HEADER

The CN0172 has three Acceleration Time ranges and four Maximum Frequency (speed) ranges. These are selected by installing jumpers on the Range Option Header. The jumper position for each option is indicated on the cover of the CN0172 next to the header. The illustration here has a frequency of 100 KHz and an accelerate time of .5-10 seconds.

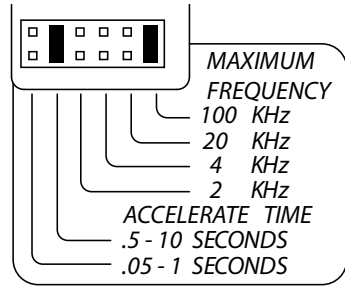

The two left columns of pins on the header select the acceleration range (zero speed to full speed). Ranges of .05-1 seconds or .5-10 seconds may be selected as indicated. **Without a jumper, the CN0172 selects a range of .005-.1 seconds.** The Acceleration Time selection in conjunction with the Acceleration Slope Trimpot setting determine the time it will take to accelerate from zero to full speed.

The four right columns of pins on the header set the speed (Maximum Frequency) of the control. This is the frequency of the pulses (after acceleration) going to the motor when the Maximum Speed Trimpot is turned fully clockwise. The available frequencies are 2, 4, 20 and 100 KHz. **One of the four must be selected for the CN0172 to operate.**

DECADE SWITCHES

The number of preset pulses to be output for one index cycle is set via these toggle switches. The six decade switches provide a range of 0 to 999,999 steps. Each digit is set by the code sequence shown here and on the cover of the CN0172. Use a small screwdriver or a pencil to set the switches. Press down on the side of the toggle (open or closed) desired. Leading zeros must be set to "0".

	SWITCH			
	1	2	3	4
0	OPEN	OPEN	OPEN	OPEN
1	OPEN	OPEN	OPEN	CLOSE
2	OPEN	OPEN	CLOSE	OPEN
3	OPEN	OPEN	CLOSE	CLOSE
4	OPEN	CLOSE	OPEN	OPEN
5	OPEN	CLOSE	OPEN	CLOSE
6	OPEN	CLOSE	CLOSE	OPEN
7	OPEN	CLOSE	CLOSE	CLOSE
8	CLOSE	OPEN	OPEN	OPEN
9	CLOSE	OPEN	OPEN	CLOSE

SETTING:
9,386



SETTING:
125,470



This illustration shows two examples of Decade Switch settings. The darkened side of the switch indicates the "down" side of the toggle.

EXTERNAL SWITCH CONNECTOR (OPTIONAL)

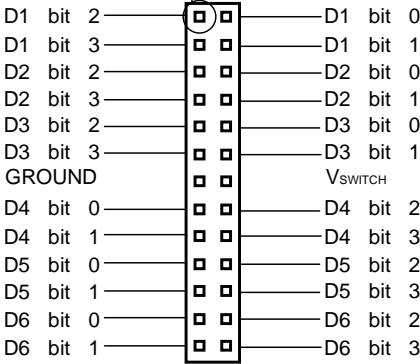
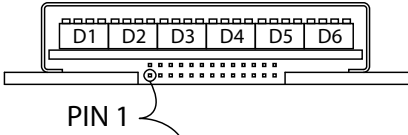

The CN0172 may be ordered with an optional header for applications where external thumbwheel switches are preferred to the on-board decade switches. A microprocessor or programmable controller may also use this as a means of sending preset pulse data to the indexer.

The connector is a dual rail terminal (13 x 2) on .1 inch centers. A standard 26 pin IDC socket and ribbon cable may be used to connect the thumbwheel switches to the connector.

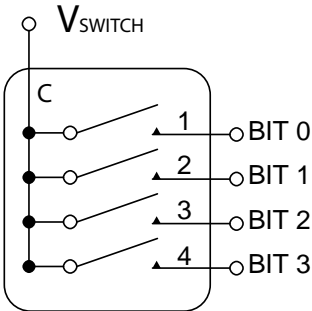

The thumbwheels must be 10 position Binary Coded Decimal with a single common. Connect the switches as shown here.

The on-board decade switches must all be set to '0' when the External Switch Connector is used.

INPUT/OUTPUT CONNECTOR

No terminals are required on the wiring to the CN0172. The recommended wire size is 16-22 gauge. Either stranded or solid conductor wire may be used. The insulation should be stripped back .25 inches before insertion into the connector block. The pin assignments and functions of the Input/Output Connector are described in the following sections.

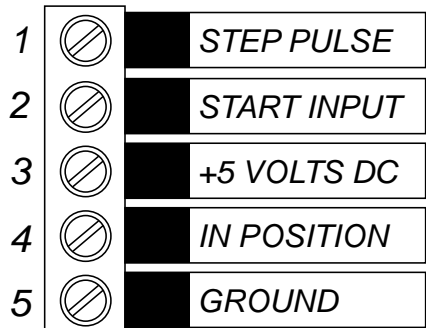

STEP PULSE**TERMINAL 1**

This TTL compatible output provides the pulse output from the CN0172 to the step pulse input of the step motor drive. The output is TTL and 5V CMOS compatible, and may be used with opto-isolated drive inputs. Maximum output frequency is 100 KHz (see Range Option Header). The number of preset pulses for each index cycle is determined by the configuration of the Decade Switches.

START INPUT**TERMINAL 2**

A high to low logic transition on this input initiates the index cycle. A single pole, single throw (SPST) momentary switch connected to Ground (Terminal 5) is normally used to activate the Start Input. The input is TTL and 5V CMOS compatible and has an internal pull-up resistor.

+5 VDC**TERMINAL 3**

This is the positive power supply input to the CN0172. The control requires a 5 volt DC regulated power supply. The maximum current draw for the indexer is 100 milliamps.

If a Centent Company step motor drive is used, connect the 5 volt output from the power supply to the +5 VDC terminal on the drive. This provides the voltage necessary for the opto-coupler in the drive.

IN POSITION**TERMINAL 4**

This output indicates when an index cycle has completed. The output goes high (5 VDC) simultaneously with the start of an index cycle and stays high for the duration of the move. At the conclusion of the index cycle, the output goes low (0 VDC) again; indicating readiness to repeat the cycle. The In Position output is TTL and 5V CMOS compatible and has an internal pull- up resistor.

GROUND**TERMINAL 5**

Terminal 5 is the power supply return for the CN0172. All inputs and outputs are referenced to this potential. The Ground and +5 Volts DC (Terminal 3) power supply leads to the CN0172 should go directly to the supply.

Do not daisy-chain power supply leads to or from other devices.

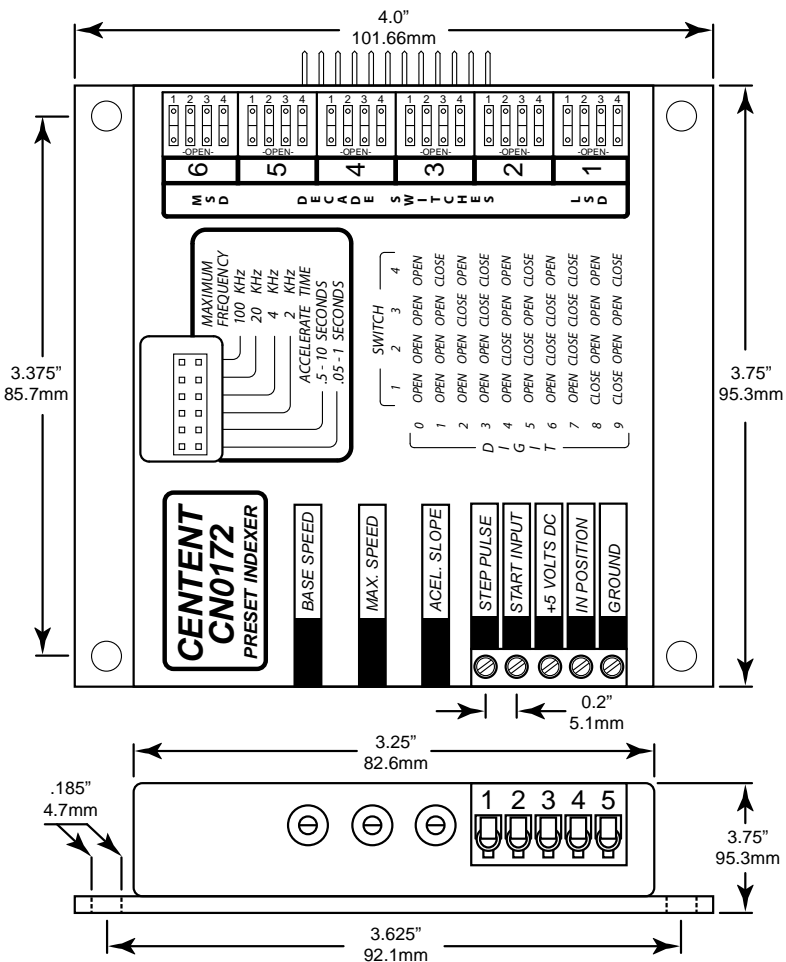

SPECIFICATIONS

	MIN.	MAX.	UNITS
POWER SUPPLY			
Voltage	4.5	5.5	VDC
Current	--	100	MA
STEP PULSE OUTPUT			
Output Voltage	0	5	VDC
Duty Cycle	50	50	%
Position	0	999,999	Pulses
Frequency (Velocity)	0	100	kHz
Acceleration	.005	10	seconds
ENVIRONMENTAL			
Operating Temperature	0	+70	°C
Weight	162	198	grams
Terminal Screw Torque		4.5	lb/in