

# OPERATING MANUAL CN0182 SERVO DRIVE

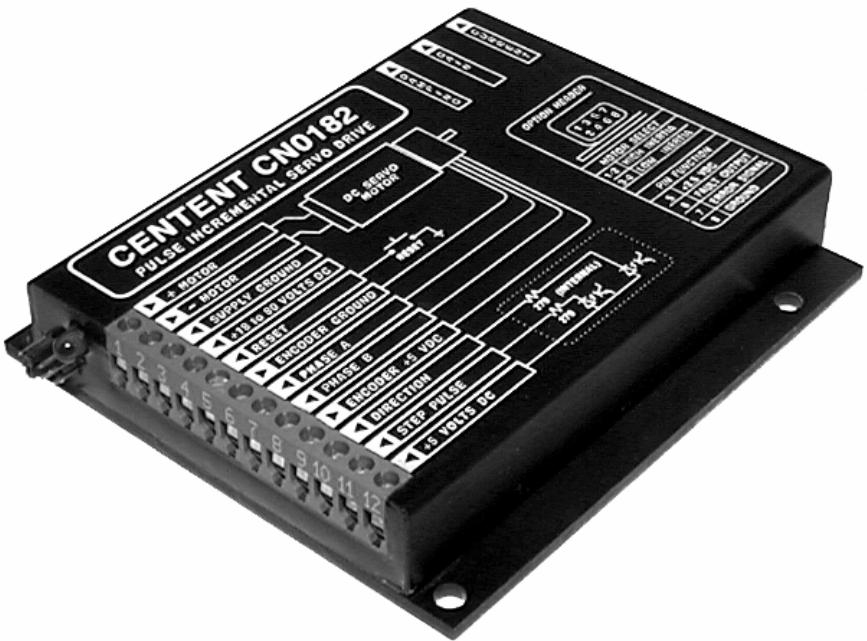

## CN0182 PULSE INCREMENTAL SERVO DRIVE

This manual contains information for installing and operating the following Centent Company product:

CN0182 Servo Drive

---

Centent and the Centent Company logo are trademarks of Centent Company. Other trademarks, tradenames, and service marks owned or registered by any other company and used in this manual are the property of their respective companies.

---

Copyright © 2011 Centent Company  
3879 South Main Street  
Santa Ana, CA 97207  
All Rights Reserved

**CONTENTS**

<b>GENERAL DESCRIPTION .....</b>	<b>1</b>
<b>LOCATION OF COMPONENTS .....</b>	<b>2</b>
<b>GETTING STARTED.....</b>	<b>3</b>
<b>QUICK SETUP .....</b>	<b>3</b>
<b>THEORY OF OPERATION .....</b>	<b>4</b>
<i>Main Elements.....</i>	<i>4</i>
<i>Auxiliary Elements .....</i>	<i>5</i>
<i>Current Limit .....</i>	<i>7</i>
<i>Protection Circuits.....</i>	<i>8</i>
<b>TERMINAL BLOCK FUNCTIONS</b>	
<i>Motor Group.....</i>	<i>10</i>
<i>Power Supply Group .....</i>	<i>11</i>
<i>Encoder Group.....</i>	<i>12</i>
Sine-Cosine Encoders .....	14
TTL Encoders .....	14
<i>Command Group.....</i>	<i>15</i>
<b>OPTION HEADER .....</b>	<b>17</b>
<i>System Inertia.....</i>	<i>17</i>
<i>Position Error.....</i>	<i>18</i>
+2.5V Reference .....	18
<i>Current Monitor .....</i>	<i>18</i>
<i>Fault Output.....</i>	<i>19</i>
<i>Reset Input.....</i>	<i>20</i>
+12 Volt Test.....	20
<i>Encoder Jumper.....</i>	<i>20</i>
Ground.....	20
<b>TUNING THE CN0182 SERVO DRIVE</b>	
<i>Current Trimpot.....</i>	<i>21</i>
<i>Gain Trimpot.....</i>	<i>22</i>
<i>Damping Trimpot.....</i>	<i>22</i>
<i>Integral Coefficient.....</i>	<i>23</i>
<i>Servo Loop Tuning .....</i>	<i>23</i>
<i>Interpreting Figure 12 – Optimum Damping.....</i>	<i>27</i>
<i>Picking A Motor .....</i>	<i>27</i>
<i>Motor Fundamentals.....</i>	<i>28</i>
<b>SPECIFICATIONS.....</b>	<b>31</b>
<b>FULL SCALE DRAWING.....</b>	<b>32</b>



## GENERAL DESCRIPTION

The CN0182 is a closed-loop PID (proportional-integral-differential) positioning servo drive that provides closed-loop control of brush-type DC servo motors. The power amplifier is an 'H' bridge utilizing MOSFET technology. The drive is capable of delivering up to 20 amps of continuous current to the motor. Motion instructions are sent to the CN0182 as Step and Direction in a pulse train format.

The CN0182 operates on a single voltage DC power supply ranging between 18 and 80 volts DC. The power supply voltage is determined by the motor's rated voltage. The power supply may be regulated or unregulated.

The motor driven by the CN0182 must be equipped with an incremental encoder with either a digital (TTL) or analog (sine-cosine) output. Analog encoders with  $\pm 1$  volt outputs can be connected directly to the CN0182. Analog encoders that do not comply with this voltage specification may be used but will require external amplification or attenuation to interface to the CN0182.

The CN0182 also facilitates step motor to servo motor conversions since it is controlled by a step motor indexer, pulse generator or motion controller, like a step motor drive. The servo motor exhibits holding torque, velocity, tracking, incremental motion and no minimum operating speed, while retaining the advantages of a DC servo motor such as increased high speed torque, absence of vibration and low heating. The upgrade from stepper to servo retains the existing indexer and control software while providing all the advantages of a closed loop servo motor system.

Torque and loop stability are controlled by trimpots built into the drive. A screwdriver is used to set motor current and tune the servo response of the drive.

Over-temperature and under-voltage protection is also built in. Upon sensing either of these fault conditions, the CN0182 removes power from the motor, guarding both the drive and the motor from damage. A light emitting diode (LED) provides visual indication of the fault condition.

The CN0182 is compact, measuring 4.75" x 4" x 0.85" (121mm x 102mm x 22mm). It comes encapsulated in a heat conductive epoxy and encased in an anodized aluminum cover. This results in an environmentally rugged package that resists abuse and contamination.

## CN0182 PULSE INCREMENTAL SERVO DRIVE

### LOCATION OF COMPONENTS

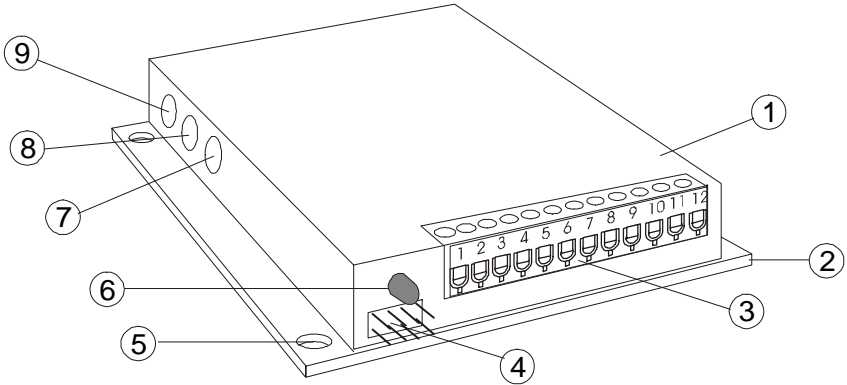

Figure 1

#### (1) MODULE

The CN0182 is encapsulated in epoxy and encased in an anodized aluminum cover. Information is printed on the cover for the configuration of the Option Header and for the electrical connections to the drive.

#### (2) MOUNTING PLATE (5) MOUNTING HOLES

The temperature of the drive must never be allowed to exceed 70° C (158° F). The Centent HSK heat sink kit may be ordered if additional heat sinking is required. Four mounting holes on 3.625" centers are provided to secure the drive to the heat sink or user equipment.

#### (3) TERMINAL BLOCK

A 12 position terminal block provides direct electrical connections to the drive; just strip the wire, insert and tighten the screw. The motor, power supply, encoder and indexer interface are accessed through this connector. The function of each terminal is printed on the cover adjacent to the screw. Do not over-tighten the screws, a torque-limit driver is recommended.

#### (4) OPTION HEADER

The user must configure this header for encoder type and system inertia. Position Error, Fault output and Reset input functions are also available. Header pin assignments are printed on the cover of the drive.

#### (6) FAULT LED

The LED (light emitting diode) is a visual indicator of the Fault Output. The LED is on when the Fault Output pin on the Option Header is active.

#### (7) DAMPING TRIMPOT (8) GAIN TRIMPOT (9) CURRENT TRIMPOT

These built-in trimpots are for setting motor current and tuning the servo response of the drive. Use a small screwdriver to turn the trimpots. Do not over-torque the trimpots.

## GETTING STARTED

Five things are needed to construct a complete closed-loop servo drive system:

1. CN0182 Drive
2. Permanent magnet brush-type DC servo motor
3. Dual channel encoder (TTL or sine-cosine type)
4. DC power supply
5. Step and Direction pulse source (Indexer)

## QUICK SETUP

The following steps will ensure a successful installation:

- Choose a motor adequate in size for the application
- Mount the desired encoder to the motor
- Choose a power supply with a voltage equal to the motor's rated voltage and a current capability equal or greater than the application will require
- Turn the CN0182 Current Trimpot completely clockwise (CW)
- Turn the CN0182 Gain Trimpot to the 9 o'clock position
- Turn the CN0182 Damping Trimpot to the 11 o'clock position
- Jumper the CN0182 System Inertia pins on the Option Header to Low Inertia
- Connect the power supply, encoder and motor to the CN0182 Drive
- Apply power temporarily and observe the motor and the Fault LED
- If the motor jumps and the Fault LED lights, reverse the motor leads
- Connect the Step And Direction source (Indexer) to the CN0182 Drive

# CN0182 PULSE INCREMENTAL SERVO DRIVE

## THEORY OF OPERATION

The block diagram in Figure 2 shows the components of the CN0182 servo drive.

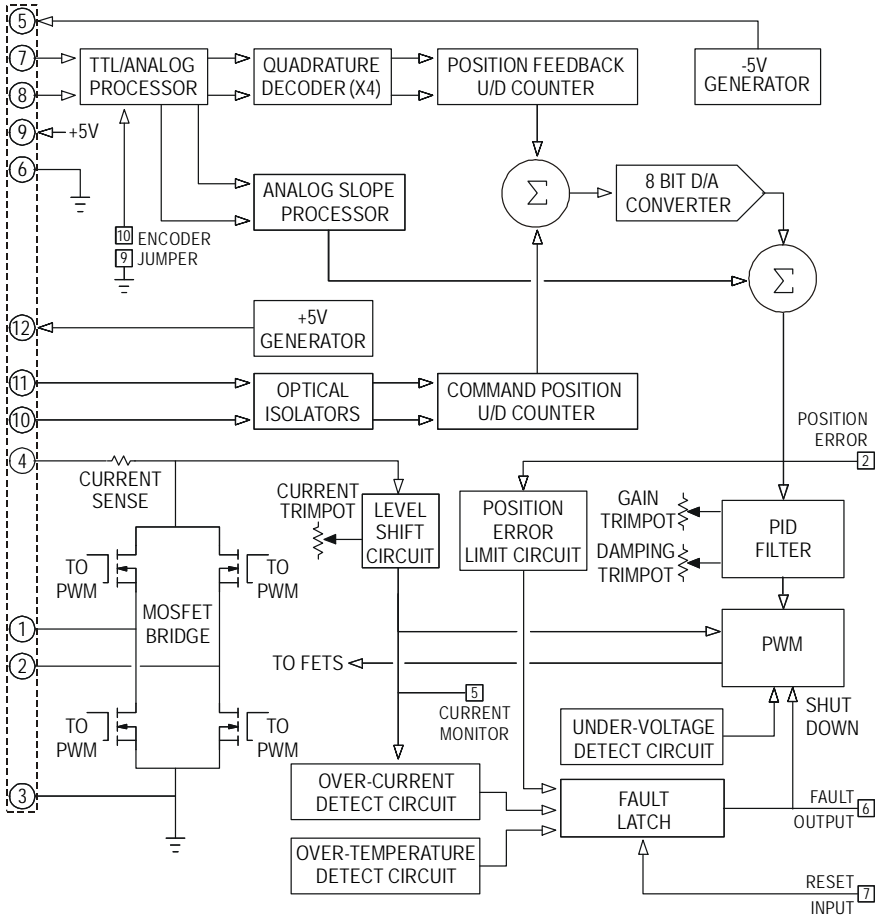

Figure 2

### MAIN ELEMENTS:

The Command Position U/D Counter is updated by the Step and Direction inputs passed through the Optical Isolators. The Position Feedback U/D Counter is updated from the Feedback Encoder. The difference between the two is the Position Error and is applied to the 8 Bit D/A Converter.

## CENTENT COMPANY

The PID Filter separates this signal into its proportional, integral and differential components. The proportional and differential components have adjustable gain, set by the Gain and Damping Trimpots. The integral component has a fixed gain. The trimpots control loop stability; their settings are determined by motor and load properties. The PID components are summed and applied to the Pulse Width Modulator (PWM). The PWM converts the PID Filter output voltage into a digital form suitable for a switching amplifier.

The MOSFET Bridge is a high power (80 volts, 20 amps) switching amplifier that drives the motor.

### AUXILIARY ELEMENTS:

The TTL/Analog Processor processes the quadrature encoder inputs through the Quadrature Decoder into a form usable by the drive. It accepts either TTL digital encoders or analog sine-cosine encoders depending on the settings of the Encoder Jumper on the Option Header.

If a sine-cosine encoder is selected, the TTL/Analog Processor also passes data to the Analog Slope Processor. The Analog Slope Processor uses the sine and cosine waveforms to interpolate position between encoder counts. The interpolation signal is summed with the Position Error to form a continuous, smooth position error, as shown in Figure 3.

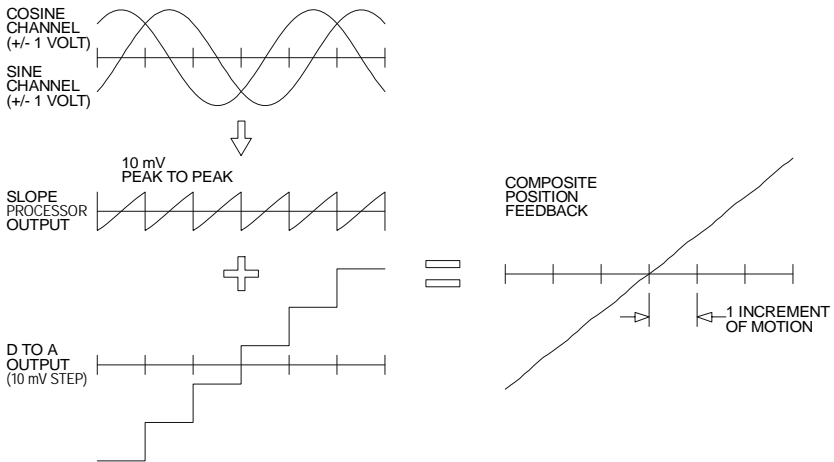

Figure 3

The use of a sine-cosine encoder has significant advantages over a digital encoder. Because a digital encoder can only update the Command Position U/D Counter on the encoder signal edges, the motor position “bounces” between the two adjacent encoder counts when no step

## CN0182 PULSE INCREMENTAL SERVO DRIVE

pulses are being sent. This results in an audible squeal and a vibration equal to one encoder count. Since a sine-cosine encoder signal contains continuous position information between encoder counts, the motor will be absolutely still when no step pulses are being sent.

At low speeds where the motion is still incremental (move one step, stop and wait for the next step), a sine-cosine encoder will result in much smoother operation since each step will be better damped.

A sine-cosine encoder makes it possible to position the motor to any location, not just the encoder count edge locations. A 500 count digital encoder results in 2000 resolvable locations (0.18 degree resolution), but if a 500 line sine-cosine encoder is used, there is also additional position information between each count location. This interpolated position feedback can be utilized by driving the Position Error pin on the Option Header (Pin 2).

One example, shown in Figure 4, multiplies the encoder line count by a factor of ten. A 500 line sine-cosine encoder has the equivalent resolution of a 5000 count digital encoder. This results in 20,000 resolvable locations. The user's U/D Counter divides the Step count by 10 and acts as a low resolution D/A Converter. The full-range output of the D/A is scaled to equal a one count Position Error step (10 mV), and is summed with the Position Error voltage.

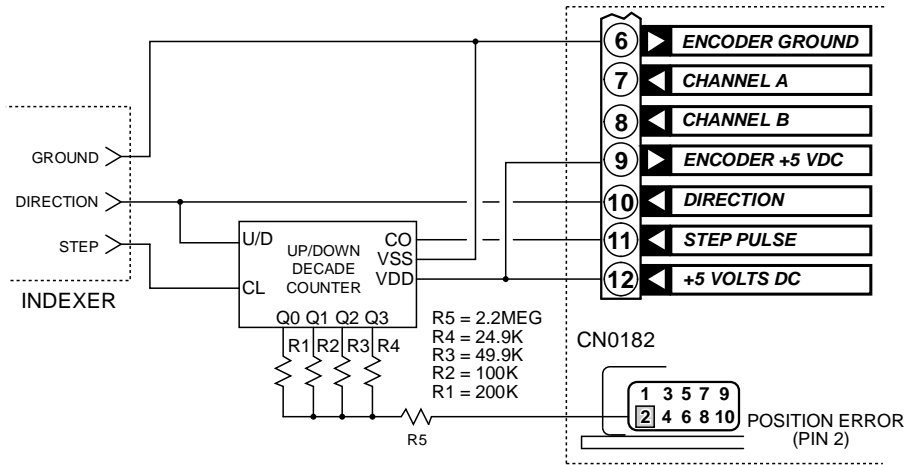

Figure 4

A second example, illustrated in Figure 5, positions a servo motor using a relatively coarse (inexpensive) sine-cosine encoder and does the fine positioning by driving the Position Error Pin either manually using a joystick or a potentiometer, or automatically with a user's closed loop signal. This is represented by P1 in Figure 5. The required manual adjustment range can

be set from one encoder count to a maximum of  $\pm 128$  encoder counts, depending on the value of the Scaling resistor. In either case, the adjustment sensitivity has infinite resolution.

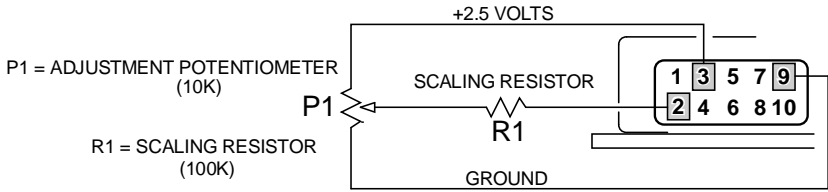

Figure 5

Sine-cosine encoders usually require plus and minus power supply voltages for proper operation. The CN0182 has an on-board  $-5$  V Generator as well as a  $+5$  V Generator to meet the requirements of both types of encoders.

If a sine-cosine encoder is used, care must be taken to accurately adjust both channels to the required  $\pm 1$  volt signal amplitude in order to take advantage of interpolated accuracy. Follow the encoder manufacturer's recommended calibration procedures.

If the Position Error Pin is driven, care must be taken to keep noise out of this node. The input impedance is 100K ohms in parallel with 100 pF. Precautions include shielding the leads and keeping their lengths short. Use the encoder power supply ground (Terminal 6) as a common for external circuitry. Do not put any capacitors on the Position Error Pin.

Failure to follow these precautions will result in unstable operation and probable Fault Protect shutdown.

#### CURRENT LIMIT:

Motor current is sensed across a Current Sense resistor located at the power supply end of the MOSFET Bridge. The Current Sense resistor serves the dual purpose of sensing motor current for current limiting in normal operation as well as sensing short circuit conditions for the protection circuit.

Because of the location of the Current Sense resistor, the voltage is passed through the Level Shift Circuit to reference it to ground. The motor current is available at the Current Monitor Pin on the Option Header (Pin 5). The scale is 10 amps per volt.

Motor current is limited on a pulse by pulse basis by the PWM. The Current Trimpot located on the side of the drive sets the current limit. The range is from zero to 20 amps. Generally, the current should not exceed the motor's rated stall current. Setting the current limit lower will limit the motor's available torque and thus its ability to follow Step Pulse commands.

## PROTECTION CIRCUITS:

The CN0182's response to any fault condition is to turn-off the power transistors that drive the motor and turn on the Fault Led and the Fault Output Pin on the Option Header (Pin 6).

A major part of the protection loop is the Fault Latch. Its function is to “remember” even momentary fault conditions, such as a short-circuit, and keep the drive in the protected “off” state until it is reset by the Reset Input (Pin 7) or the power supply is recycled. All fault conditions except under-voltage, which is handled by the Under-Voltage Detect Circuit, pass through the Fault Latch. The fault conditions are:

- **Over Current**

The Over-Current Detect Circuit monitors the current passing through the drive. When excessive current occurs, the Fault Latch is set. This will occur if the motor leads short together or to ground. Normal operation of very high current motors will not set the Fault Latch because the Current Trimpot limits operating current to 20 amps, which is below the Over Current Detect trip point.

- **Over Temperature**

The Over-Temperature Detect Circuit monitors the drive's temperature. If the temperature of the drive exceeds 70° C, the circuit sets the Fault Latch. This might occur if the motor operates continuously at high currents, the drive is poorly heat-sunk or the ambient temperature is very high. If the cause is high motor current, consider the possibility the motor may also be overheating.

The protection provided by Over Temperature Detect Circuit is not designed as a substitute for adequate heat sinking. Repeatedly allowing the drive to overheat and trip the Fault Latch will cause thermal stress that may eventually lead to failure of the drive. Under no circumstances allow the temperature of the CN0182 to reach 70° C. For very high current applications, a fan may also be necessary to provide forced air circulation to the heat sink.

The HSK heat sink kit is available to lower the operating temperature of the drive. The kit consists of heat sink, side rails and screws to secure the drive and the side rails. The side rails are reversible, allowing the two mounting configurations shown in Figure 6. Contact Centent Company to order the HSK heat sink kit.

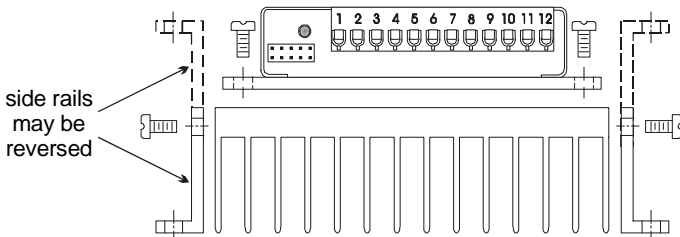

Figure 6

- **Position Error Limit**

The Position Error Limit Circuit monitors the difference between the command position and the actual motor position. If this difference exceeds  $\pm 128$  counts, the servo lock is considered broken and the position can not be recovered. The result would be a runaway motor and possible damage to system components. Before this condition is reached, the Position Error Limit Circuit sets the Fault Latch, shutting down the drive.

Possible causes of a Position Error Limit trip are many; the most common, and their remedies are:

1. **Unstable Loop**

Improperly set Gain and Damping trimpot settings are the causes here. This generally shows up during the initial setup phase. If the damping setting is too low, the motor will begin to oscillate. When the oscillation amplitude reaches  $\pm 128$  counts, the CN0182 will shut down. Increase the damping setting and try again. If the gain setting is too low, the drive will be sluggish in responding and an error approaching  $\pm 128$  counts can develop. Increase the gain setting slightly and try again.

2. **Broken Loop**

The CN0182 is part of a closed-loop system. The CN0182 drives the motor, the motor turns the encoder and the encoder sends feedback information back to the CN0182, completing the loop. Any malfunction in this loop will result in a position error and a protective shutdown. Verify that the encoder connections to the drive are correct and that there are no breaks in the wiring or terminals.

3. **Insufficient Torque At High Speed**

DC motor torque is at a maximum at zero speed (stall torque) and linearly decreases to zero at the motor's maximum speed (no-load speed). Consequently, the motor's ability to provide torque decreases as speed increases. The options here are to increase the power supply voltage or use a motor with a higher no-load speed.

Another possible cause may be the frequency limit of the encoder. Many encoders have a maximum frequency of 100 kHz, or 400,000 counts per second. If a high line count encoder is used at high speed, this limit may be exceeded. For instance, a 2500 line encoder would be at this limit at 2400 RPM ( $60 \times 100,000 / 2500$ ).

4. **Insufficient Torque At Low Speed**

Motor torque is directly proportional to motor current. If the motor is unable to carry a load at low speed, check to see if the Current Trimpot is set too low. If the motor's stall current is less than 20 amps, setting the Current Trimpot beyond the stall current will not help, since it is the motor and not the drive that limits current. The options here are to get a higher stall current motor (up to 20 amps) or a motor with a higher torque constant.

## CN0182 PULSE INCREMENTAL SERVO DRIVE

### TERMINAL BLOCK FUNCTIONS

Wire of 16-22 gauge is recommended for the connections made to the CN0182. The insulation should be stripped back 0.25 inches before inserting the wire, to assure good contact with the connector. No additional terminals or connectors are required on the ends of the wire. Care must be taken not to damage the screw terminals by over tightening. If possible use a torque-limiting driver, set to a maximum of 4.5 lb.- in.

The 12 position Terminal Block is grouped by function; the four groups are Motor Group, Power Supply Group, Encoder Group and Command Group. A detailed description of each follows:

#### MOTOR GROUP

#### TERMINALS 1-2

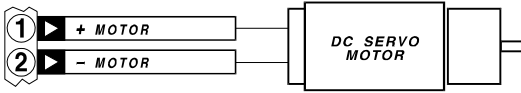

Terminal 1 is the "plus" motor connection and Terminal 2 is the "minus" motor connection.

The motor will rotate clockwise when the Direction Input (Terminal 10) is at a logical "0" (low).

The motor must be a permanent magnet, brush-type DC servo motor. Preferred motors have a laminated iron armature. The drive requires a minimum inductance of 500  $\mu\text{H}$ . Pancake, cup and other ironless armature motors have very low inductance (less than 500  $\mu\text{H}$ ) and consequently will have excessive ripple current. This ripple current will cause considerable motor heating. If these type motors are used, insert a 500  $\mu\text{H}$  inductor in series with the motor. Make sure the inductor is rated for the maximum current the motor will carry.

The output is a pulse-width modulated (PWM) 20 kHz waveform with voltage amplitude equal to the power supply voltage. The maximum output current of the drive is  $\pm 20$  amps.

If motor wires longer than 3 feet are required, use a shielded cable. This will limit the amount of radiated electrical noise that could interfere with other equipment. A three conductor, shielded cable is recommended. The suggested wiring configuration is shown in Figure 7.

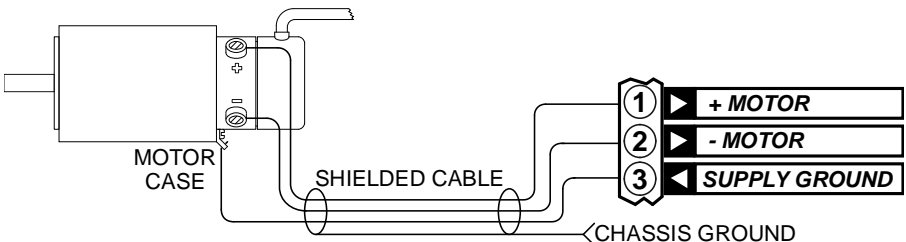

Figure 7

Two of the wires go to the motor terminals while the third connects to the motor's case at one end and to the CN0182's Supply Ground (Terminal 3) at the other.

**The shield should be connected to the chassis ground at one end only!** This way the shield cannot conduct and radiate ground-loop currents.

## POWER SUPPLY GROUP

## TERMINALS 3-4

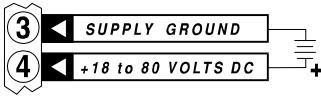

The CN0182 operates on a single voltage DC power supply, ranging between 18 VDC and 80 VDC.

The power supply may be regulated or unregulated. If the power supply is regulated, it must have at least 1000  $\mu\text{f}$  of capacitance on the output.

Terminal 4 is the positive input and Terminal 3 is the ground return. The choice of power supply voltage and current is based on the motor selected. The voltage should be high enough to run the motor at the maximum speed required by the application. A good first choice is a power supply voltage equal to the motor's rated voltage plus two volts to account for the losses in the drive.

The current rating of the power supply must be sufficient to meet the torque requirements of the application. A good choice is a power supply with a current rating equal to the motor's stall current.

Most motors have a stall current ten times higher than the motor's continuous rated current. The continuous rated current is based on the motor's ability to safely dissipate heat. However for short periods of time, while accelerating or decelerating, the motor can handle much higher currents without harm. The power supply must be rated to meet this temporary current draw.

This makes the power supply up to ten times larger than it otherwise would need to be, since conventional power supplies cannot deliver current ten times their rated continuous current. One possible way around this problem is shown in Figure 8.

The power supply transformer, rectifiers and filter capacitor are sized to provide current that is slightly greater than the motor's continuous rated current. A rechargeable battery, (preferably nickel-cadmium), with a voltage rating a little below the power supply's voltage is placed across the power supply output through a diode.

While the motor is drawing current less than the continuous rated current, the diode is reverse biased and no current flows from the battery.

## CN0182 PULSE INCREMENTAL SERVO DRIVE

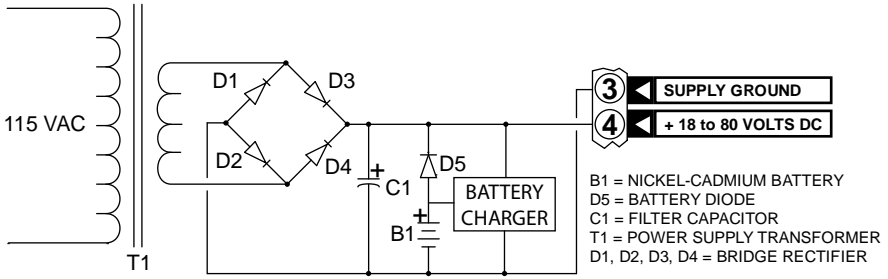

Figure 8

When the motor begins to draw current in excess of the power supply rating, the power supply voltage begins to sag and the diode begins to conduct current from the battery, supplying the temporary current necessary for acceleration. Once the load eases, the power supply voltage rises and turns off the current from the battery. The trickle-charger restores the charge drained from the battery.

High currents through long, light gauge wires will result in a significant voltage drop. This voltage drop can be enough to cause the CN0182 go into Under-Voltage Protect and reset. This will then cause the motor to develop a Position Error Limit and Fault Output. The result is the motor will have less performance than expected since it would have to be accelerated more slowly to avoid drawing this level of current.

### IMPORTANT!

Power supply wires must be heavy (16 gauge maximum) and as short in length as possible. This is especially true for large, high current motors.

## ENCODER GROUP

## TERMINALS 5-9

Terminals 5 through 9 form the encoder interface, providing closed loop feedback to the drive. The CN0182 provides regulated 5 volt outputs to power digital or analog encoders.

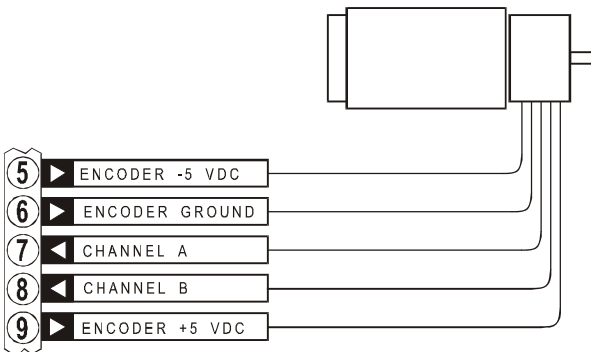

Analog encoders normally require a bipolar power supply while digital encoders will generally use only a +5 volt supply.

Terminal 9 is the +5 VDC encoder power supply output required by digital (TTL) quadrature encoders. The output provides a maximum of 100 mA of current. Most TTL encoders

## CENTENT COMPANY

require substantially less power supply current to operate.

Terminal 5 provides a  $-5$  VDC power supply @  $50$  mA maximum. This allows the CN0182 to interface to analog (sine-cosine) encoders. These types of encoders need bipolar (+ and -) power supplies. Since most encoders use the  $+5$  volt supply to power their LEDs, the  $-5$  VDC current rating of  $50$  mA is more than adequate.

Terminal 6 is the encoder ground. Use this terminal for the encoder return and ground shield. Do not use Terminal 3 for encoder return. Terminal 6 connects to a “quiet” ground internally while Terminal 3 has considerable ground noise that would compromise the noise immunity of the encoder signal lines and cause erratic operation of the motor.

Terminals 7 and 8 are the channel inputs from the encoder. The inputs can be either TTL (zero VDC,  $+5$  VDC) levels or analog  $\pm 1$  volt amplitude sine-cosine inputs. The Encoder Jumper on the Option Header (pins 9-10) selects between digital and analog encoder operation. With no jumper in place the inputs must be TTL level signals; with a jumper present the inputs are analog.

For analog sine-cosine encoders the CN0182 requires the channel outputs to be  $\pm 1$  volt in reference to ground. Encoders that do not comply will require external amplification or attenuation to interface to the CN0182.

Analog and digital encoders may be powered directly from the CN0182 if they draw less than  $100$  mA @  $+5$  V and  $50$  mA @  $-5$  V. Encoders requiring higher voltage or current must be operated by external power supplies.

A special TTL encoder case occurs if the encoder outputs are open collector. Open collector outputs must have pull-up resistors in order to function. Figure 9 shows how these resistors are to be connected.

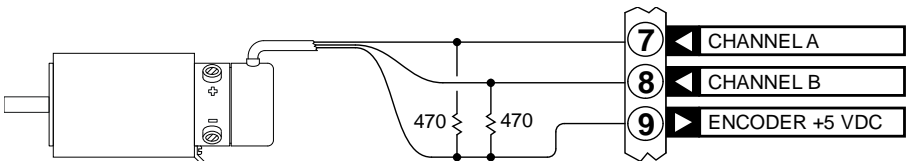

Figure 9

The CN0182 performs a “times 4” decoding, resulting in a resolution four times greater than the line count of the encoder. As an example, a  $1000$  count per revolution encoder will result in  $4000$  positions per revolution.

## CN0182 PULSE INCREMENTAL SERVO DRIVE

While more common, digital (TTL) encoders have the drawback of "hunting" between adjacent encoder counts. This manifests itself as buzzing or humming, and is most noticeable when the motor is stopped. Analog encoders avoid this by providing continuous position information between encoder counts. The result is silent and stable operation while the motor is stopped.

The CN0182 has been tested with numerous TTL and analog type encoders. Below are several encoders that have performed satisfactorily with the CN0182. This is by no means a complete list of acceptable encoders.

SINE - COSINE ENCODERS		
	COMPUTER OPTICAL PRODUCTS	DYNAMICS RESEARCH CORP.
<i>MODEL</i>	CP-800-5000-F	T23DA4EDB2V-1000
<i>LINES</i>	5000 (20,000 counts / rev)	1000 (4000 counts / rev)
<i>CN0182</i>	<i>ENCODER LEAD WIRE</i>	<i>ENCODER LEAD WIRE</i>
<i>Terminal 5</i>	WHITE/BROWN (stripe)	BLUE
<i>Terminal 6</i>	GRAY/WHITE (stripe)	BLACK
<i>Terminal 7</i>	WHITE/ORANGE (stripe)	WHITE
<i>Terminal 8</i>	BLUE/WHITE (stripe)	GREEN
<i>Terminal 9</i>	BROWN/WHITE (stripe)	RED

TTL ENCODERS		
	HEWLETT PACKARD	BEI MOTION SYSTEMS CO.
<i>MODEL</i>	HEDS-5500 A06	MOD5540-25-500
<i>LINES</i>	500 (2000 counts / rev)	500 (2000 counts / rev)
<i>CN0182</i>	<i>ENCODER TERMINAL</i>	<i>ENCODER TERMINAL</i>
<i>Terminal 5</i>		
<i>Terminal 6</i>	PIN 1	PIN 1
<i>Terminal 7</i>	PIN 2	PIN 2
<i>Terminal 8</i>	PIN 3	PIN 3
<i>Terminal 9</i>	PIN 4	PIN 4

## COMMAND GROUP

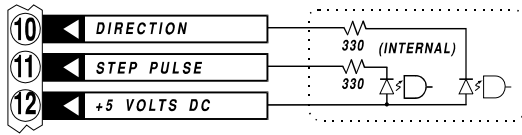

## TERMINALS 10-12

The Step Pulse, Direction and +5 VDC inputs form the motion command interface to the CN0182.

The motor will move one encoder increment for each step pulse received. The motor moves in a clockwise rotation if the Direction Input is low at the moment of the step pulse input and counter-clockwise if the Direction input is high.

The inputs are optically isolated from the rest of the drive circuitry to provide noise immunity. The high currents, voltages and fast edge times of the motor amplifier generate considerable electrical noise that would create problems with the indexer logic circuits. Optical isolation keeps this noise from getting into the indexer.

An indexer or other pulse source generates Step and Direction input to the drive by sinking the cathodes of the optical isolator LEDs to ground. The external +5 Volts DC used to power these diodes must be provided by the indexer or pulse source.

The CN0182 uses high-speed opto-isolators that can pass pulse trains up to 1 MHz. It is necessary that the Step and Direction Inputs have rise and fall times under 50 nano-seconds to avoid false steps and erratic operation. The opto-isolator driver current sink capability must be at least 16 mA. This requirement is easily met with standard TTL or 74HC bus drivers.

**IMPORTANT!**

Do not run the Command Group wires in a common wiring harness with the Motor Group wires. Doing so will result in erratic motor behavior because capacitive coupling of motor waveforms into the Step and Direction input lines would cause false steps.

If it is necessary to run Command, Encoder or Motor wires longer than 3 feet use shielded cables. This is particularly important for the Motor wires.

Terminal 10 is the Direction Input. The state of this input is sampled on the rising edge of the Step Input and determines the direction in which the increment of motion will be taken. If the Direction Input is a logical "0", then the step will be in the clockwise direction. If it is a logical "1", (+5 VDC or open), then the step will be taken in the counter-clockwise direction.

Terminal 11 is the Step Input. A rising edge (0 to +5 VDC) on this input will result in one increment of motion. The size of this increment is determined by the encoder resolution; a 500 line encoder will yield 0.18 degrees of motion ( $360^\circ / 500 \times 4 = 0.18^\circ$ ). The direction of

## CN0182 PULSE INCREMENTAL SERVO DRIVE

motion is set by the state of the Direction Input at the time of the Step Input edge. The device connected to Terminal 11 must be capable of sinking 16 mA of current.

Terminal 12 is the +5 VDC terminal. This input is connected internally to the common anodes of the Step Pulse and Direction opto-isolator LEDs. By using a separate power supply, provided by the indexer or pulse generator, electrical isolation between the CN0182 and indexer is maintained.

Terminal 12 is not a 5 Volt output from the CN0182. A separate, external 5-Volt supply must be connected to this terminal. Do not connect Terminal 12 to Terminal 9. A suggested hook-up for the Command Group is shown in Figure 10.

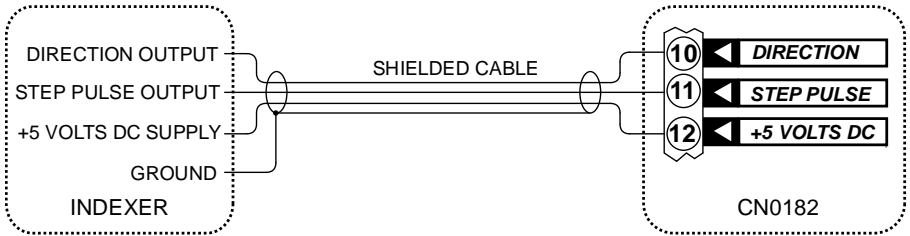

Figure 10

If power supply voltages higher than 5 VDC must be used the Step Pulse and Direction inputs will each require external series resistor to limit the current to the opto-isolators to a maximum of 10 milliamps. Do not connect a single resistor to Terminal 12 to limit current; two resistors are required, one to Terminal 10 and one to Terminal 11 (see Figure 11). In this example a 12-volt supply and 750 ohm external resistors are shown.

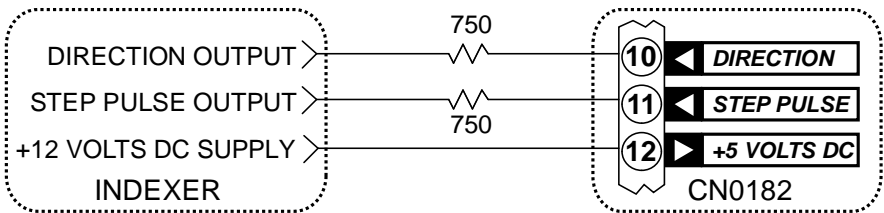

Figure 11

Resistor values for common power supply voltages are shown below:

Power Supply	External Resistors
12 volts	750 $\Omega$
18 volts	1.3 K $\Omega$
24 volts	2.0 K $\Omega$

## CENTENT COMPANY

Other supply voltages may be used, see Equation 1 to determine the correct external resistor values for your supply.

$$R_{EXTERNAL} = \frac{(V_{SUPPLY} - 1.5)}{(0.010)} - 330$$

*Equation 1*

### OPTION HEADER

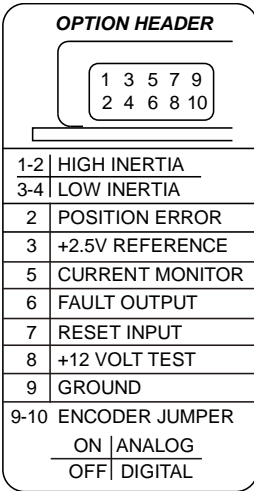

The Option Header is used to configure the CN0182 for the encoder type and inertial load as well as provide input and output functions for the drive.

This 10-position (5 x 2) connector is located on the face of the drive. Pins 1-2, 3-4 and 9-10 are designed as pairs for jumper blocks. Pins 2 and 3 also have discrete functions. Pins 5-8 have discrete functions; do not use jumper blocks for these pins.

The following section describes each function and its pin assignment.

#### SYSTEM INERTIA

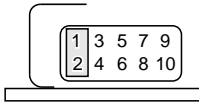

HIGH INERTIA

#### PINS 1-2 & PINS 3-4

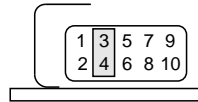

LOW INERTIA

A shorting bar supplied

with the drive is used to configure the CN0182 for load and motor inertia. High inertia is defined as load inertia greater than ten times the motor's inertia. To select high inertia, jumper Pin 1 to Pin 2. To select Low Inertia jumper Pin 3 to Pin 4. Low Inertia is the default setting.

Do not jumper both pairs of pins simultaneously. Jumper only one pair of System Inertia pins, 1-2 OR 3-4, at a time.

## POSITION ERROR

PIN 2

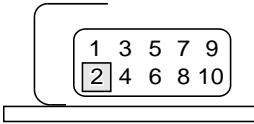

In addition to being the high inertia jumper, Pin 2 also functions as the Position Error Signal. This output is used to tune the CN0182 and observe the stability of the system. The voltage on this pin ranges from 0-2.5 volts. When the motor's position matches the command position, representing a zero position error, the voltage on Pin 2 is 1.25 volts.

Each increment of motion difference between the command position and the motor's actual position will add or subtract .01 volt to the voltage on Pin 2. A clockwise error will add .01 volt while a counter-clockwise error will subtract .01 volt.

A voltage above 1.25 volts indicates the actual motor shaft position is located clockwise from the command position. A voltage below 1.25 volts indicates the actual position is located counter-clockwise of command position. The magnitude of the Position Error is approximately 10 mV per encoder count.

The voltage on Pin 2 will be 1.25 volts DC, whether the motor is turning or not. Only a change in load conditions such as an abrupt speed command change, a change in the direction command while the motor is turning or a suddenly applied or removed load will cause a transient deviation from this value. Once the motor adjusts itself to the new conditions, the voltage will return to 1.25 volts.

The stability of the servo can be determined by observing The Position Error voltage with an oscilloscope while the motor is subjected to abrupt load changes. This can be done by repeatedly changing the direction command while the motor is turning. See page 23 for how to tune the servo.

## +2.5V REFERENCE

PIN 3

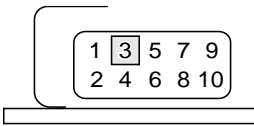

Pin 3 is a 2.5-volt reference output used to calibrate the voltage of the Position Error Signal (on Pin 2). Pin 3 shows the state of the CN0182's 2.5 VDC precision voltage reference. It may be used for external circuits as long as the load current does not exceed 1 mA. Use Option Header Pin 9 or Terminal Block Terminal 6 for Ground for the 2.5V Reference.

## CURRENT MONITOR

PIN 5

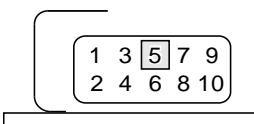

The voltage on Pin 5 is proportional to the motor current. It is made available for external monitoring of motor load, which is proportional to current.

The ratio is ten amps of motor current per one volt on the output pin. Zero voltage on the pin implies zero motor current. This voltage is the absolute value of the motor current; it is a positive voltage regardless of the direction of the motor's current. Use Option Header Pin 9 or Terminal Block Terminal 6 as Ground for the Current Monitor function.

## FAULT OUTPUT

## PIN 6

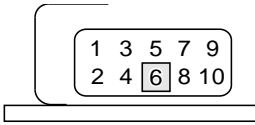

Pin 6 goes low (zero volts) when a fault condition is encountered. This output notifies the user's equipment that the CN0182 has shut down and corrective action needs to be taken. Use Option Header Pin 9 or Terminal Block Terminal 6 for Ground when monitoring the Fault Output.

The CN0182 enters a fault state under specific conditions. These conditions are:

- |                     |   |
|---------------------|---|
| 1. UNDER-VOLTAGE    | <i>Power supply voltage below 18 VDC</i>  |
| 2. OVER-TEMPERATURE | <i>Case temperature in excess of 70°C</i> |
| 3. OVER-CURRENT     | <i>Motor current in excess of 20 amps</i> |
| 4. POSITION ERROR   | <i>An error of more than ±128 counts</i>  |

The Fault LED provides a visual indication of a fault. Over-temperature, over-current and position error faults are latched faults. The Fault Output stays low; the CN0182 remains shut down. The fault state is maintained even if the condition that caused it disappears. The fault condition may only be cleared by a Reset command (Pin 7) or by recycling the power supply (power off, power on).

Repeated fault latching means there may be a problem with one or more of the following:

- motor
- motor cable
- encoder
- encoder cable
- excess motor load
- improperly tuned servo

Locate and rectify the problem(s) before continuing the operation of the CN0182. Do not allow the drive to latch repeatedly, as permanent damage to the drive, motor or power supply could result.

RESET INPUT

PIN 7

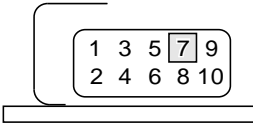

Pin 7 is normally high (5 VDC). The CN0182 will reset when Pin 7 input is taken low (shorted to ground). Use Option Header Pin 9 or Terminal Block Terminal 6 for Ground for this function.

While reset, the motor is un-powered and freewheeling. The Fault LED will be lit during a reset. A reset is used to clear a fault. Releasing the Reset Input clears the fault latch and starts normal operation.

The CN0182 performs a self-reset when it is powered up. The Fault LED will briefly light every time the CN0182 is powered up.

+12 VOLT TEST

PIN 8

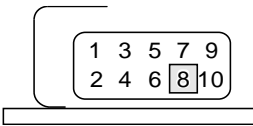

Pin 8 is connected directly to the CN0182's +12 volt regulated supply. The state of the internal 12 VDC supply may be observed on this pin. Use Option Header Pin 9 or Terminal Block Terminal 6 for Ground when monitoring the 12 VDC supply.

ENCODER JUMPER

PINS 9-10

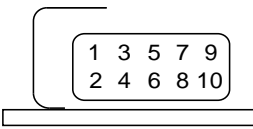

DIGITAL

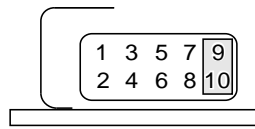

ANALOG

To operate the CN0182 with a motor equipped with an analog (sine-cosine) encoders, jumper Pin 9 to Pin 10. The CN0182 will extract additional position information from the encoder signals in this configuration. For digital (TTL) encoders, do not connect Pins 9 and 10 together. The default setting for the CN0182 is for digital encoders.

GROUND

PIN 9

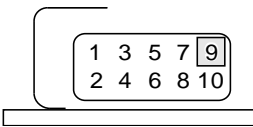

In addition to serving as a connection for analog encoder selection, Pin 9 is Ground reference for other Option Header functions. These include Position Error, +2.5V Reference, Current Monitor, Fault Output, Reset Input and +12V Test. Ground reference can also be obtained on Terminal 6 of the Terminal Block. This is the Encoder Ground. Do not use Terminal 3, Supply Ground, as ground for Option Header functions.

## TUNING THE CN0182 SERVO DRIVE

Three potentiometers are built into the CN0182 to set the motor current limit and tune the servo to the motor and load for stable operation. They are the Current, Gain and Damping trimpots. They are located on the side of the drive. The function for each trimpot is printed on the case of the CN0182.

Adjustments may be made with a small slotted screwdriver. The trimpots are  $\frac{3}{4}$  turn from CCW limit to CW limit. Care must be taken to not force the slots beyond their limits.

## CURRENT TRIMPOT

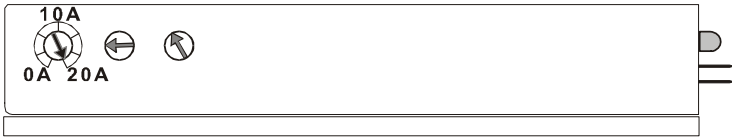

The CN0182 has a maximum current rating of 20 amps. The Current Trimpot adjusts motor current from zero to twenty amps. The trimpot is linear through its range of travel; turning the screw to the midpoint sets the current to 10 amps. The full clockwise setting is 20 amps while the full counter-clockwise setting is zero amps. Turn the trimpot clockwise to increase maximum motor current. Turn the trimpot counter-clockwise to decrease maximum motor current.

Normally the Current Trimpot is turned to its maximum setting (all the way CW). Motor torque is directly proportional to motor current. Setting a current limit below what the motor can carry will limit the motor's torque and its ability to drive a load. If a motor cannot drive the load, a rapidly increasing position error will develop, leading to a premature Position Error fault shutdown.

Motors that have a stall current less than 20 amps should draw no more than their rated stall current in normal operation. Set the Current Limit Trimpot to approximately this value to prevent over-currenting the motor should the direction be suddenly reversed. The Current Limit Trimpot should also be set to less than the maximum if the driven load might be damaged when the motor torque exceeds a certain value.

When motor current exceeds the setting of the Current Trimpot, power is interrupted and the Fault Output and Fault LED turn on. If the motor current exceeds 20 amps, regardless of trimpot setting, the Fault Output is latched and must be reset to continue operation. See Reset Input, Pin 7.

The Fault LED will light any time the CN0182 limits motor current. It will be on for the duration of current limit condition, such as a rapid acceleration or deceleration. It is a warning that a position error is developing which will lead to a Position Error Fault if further load is placed on the motor.

## GAIN TRIMPOT



The Gain Trimpot sets the proportional gain coefficient of the PID compensation loop. This acts to counteract position error introduced into the system by a disturbance. It develops a "stiffness" to hold the motor at the commanded position. The mechanical equivalent of this function is a spring. The greater the Gain Trimpot setting, the greater the "stiffness".

To increase the proportional gain coefficient, turn the trimpot clockwise. To decrease gain turn the trimpot counter-clockwise.

## DAMPING TRIMPOT

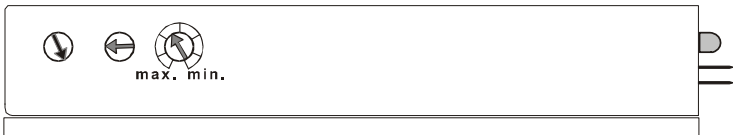

The Damping trimpot affects the dynamic behavior of the motor in response to a disturbance. The mechanical equivalent of this function is a viscous damper or shock absorber. An under-damped motor will oscillate or "ring" after a disturbance, overshooting the command position repeatedly.

If the system is severely under-damped, the oscillations will increase rapidly in amplitude until they exceed the Position Error Limit and the CN0182 shuts down.

An over-damped system will take longer than necessary to return to the command position after a disturbance. Excessive damping also causes greater motor heating and noise since any position disturbance is responded to over-aggressively.

A properly damped system will return to the command position in the shortest time after a disturbance. Turning the Damping Trimpot clockwise increases damping. Turning the Damping Trimpot counter-clockwise decreases damping.

The Damping Trimpot sets the derivative gain coefficient of the PID compensation loop. The derivative gain coefficient corrects a position error by generating a restoring component proportional to the rate of position error change; i.e. a derivative of the error.

The gain and damping settings track each other. Increasing the gain setting will require a higher damping setting; increasing the damping will require a higher gain setting. As a rule,

use the lowest reasonable gain setting, and then adjust the damping to the lowest setting possible without ringing or overshoot.

## INTEGRAL COEFFICIENT

The third element in a PID compensation loop is the integral gain coefficient. The gain is fixed for this component and is not adjustable by the user. The purpose of the integral coefficient is to “take up” or eliminate over time any remaining position error. There is always a position error that the proportional coefficient cannot remove because it becomes less effective as the position error decreases.

The integral coefficient works by “integrating” over time any remaining position error. This means any residual error becomes multiplied over time, restoring the motor to the command position with zero error. The integral gain coefficient is not settable on the CN0182.

The motor will be perfectly still when not commanded to move if sine-cosine encoders are used. This is because the integral coefficient reduces any position error to zero.

If TTL encoders are used, the motor will bounce between two adjacent encoder count edges when not commanded to move. This is because there is not position feedback information between count edges. Any residual position error, no matter how small, is multiplied over time to a level sufficient to move the motor. The motor then moves until it reaches an encoder count edge, where it reverses direction until it hits the other constraining encoder count edge, repeating the process.

Using the minimum Gain Trimpot setting for TTL encoders helps reduce bounce. The higher the gain the higher the Damping Trimpot setting, both of which contribute to how strongly and rapidly the motor will bounce between the adjacent encoder count edges. The stronger the motor bounces, the more torque is required. This results in unnecessary motor heating, vibration and audible noise.

## SERVO LOOP TUNING

A DC servo drive must be "tuned" to the application to achieve optimum system stability. This consists of adjusting the Gain and Damping Trimpots to the correct values for the particular motor and load combination the CN0182 is driving.

The tools needed are:

- A STEP and DIRECTION pulse source or 2 FUNCTION GENERATORS
- A 2 channel OSCILLOSCOPE with 10:1 probes
- A small SCREWDRIVER

Begin by connecting the power supply and the encoder to the CN0182. Do not connect the motor or pulse source yet. Jumper the Option Header for the type of encoder being used (pins 9, 10) and the expected moment of inertia. The default is Low Inertia (pins 3, 4).

Turn on the power supply. The Fault LED should light momentarily when power is applied.

Test the encoder by turning the motor shaft very slowly. The Fault LED should light when the shaft is turned more than 128 encoder counts if the encoder is working properly. This may be a very small part of a revolution of the motor shaft, about 12 degrees or 1/32 of a revolution for a 1000-line encoder.

Turn the Gain Trimpot to the “9 o’clock” position and the Damping Trimpot to the “11 o’clock” position. See the graphics on page 22 for orientation of these trimpots. They have a small arrowhead pointer at the end of the screwdriver adjustment slot. The “9 o’clock” setting of the Gain Trimpot positions the pointer parallel to the base plate of the drive with the arrow pointing to the left as you face the trimpot. The Damping Trimpot “11 o’clock” position is also shown.

Turn the power supply off and connect the motor. Turn the power supply back on. If the motor jerks momentarily and The Fault LED comes on, turn the supply off and reverse the motor lead connections.

With the power supply on, the Fault LED should be off and the motor should be stopped. It is normal for the motor to make a slight squealing sound, particularly if a TTL type encoder is used. Gently try turning the motor shaft; it should resist being turned.

Turn the power supply off. Connect the pulse source to the CN0182’s Step, Direction and +5 Volts DC inputs. If Function Generators are used, do the following:

Set both Function Generators to the square wave setting and adjust the outputs to a  $\pm 5$  volt amplitude. One generator will drive the Direction Input while the other will drive the Step Input. Set the Direction generator output to about 1 Hz.

Set the Step generator to a frequency range setting that will turn the motor about five revolutions per second full scale. This frequency depends on the encoder line count; 1000-line encoder will require 20 kHz to turn at this speed. Turn the frequency dial to the minimum on this range setting.

Connect both generators’ ground leads to the CN0182’s +5 Volts DC terminal (Terminal 12). Connect the Direction generator’s output to the Direction Terminal (Terminal 9) and the Step generator’s output to the Step Terminal (Terminal 10). Make sure both generators are on.

If an indexer is used instead of Function Generators, follow the procedure described in the Command Group section on page 15 to connect the indexer to the CN0182. The indexer must be setup to send a continuous stream of motion instructions. Each instruction should be scaled to move the motor shaft at about five revolutions per second for approximately  $\frac{1}{2}$  second. The direction of the move must alternate with each instruction. The rate of acceleration of the moves should be set to a maximum value.

Connect the oscilloscope channel 1 probe to Pin 2 (Position Error Output) on the Option Header. Connect the probe ground lead to Terminal 6 (Encoder Ground) on the Terminal Block. Connect the oscilloscope channel 2 probe to Terminal 9 (Encoder +5 VDC) on the Terminal Block and its ground lead to Terminal 12 (+5 Volts DC) on the Terminal Block.

## CENTENT COMPANY

Set the oscilloscope's Channel 1 Volts/Div to .2 volts and set Channel 2 Volts/Div to 2 volts. Zero both channels to the bottom line on the display grid. Set both channels to DC Coupling. Set the Vertical Mode to display Channel 1 only. Set the time-base Sec/Div to 10 milliseconds. Set the Trigger Source to Channel 2 and the Trigger Mode to Normal. Adjust the Trigger Level until you see a once per second sweep on the scope display.

Turn the power supply on. The motor should turn slowly and reverse direction twice a second. The oscilloscope display should show a negative going "blip" followed by a flat trace at the 1.25 volt level, or about 6.25 display grid lines up from the bottom. If the "blip" at the beginning of the trace is very small or can't be seen, slowly increase the Step generator frequency until the height of the blip is about 2 grid lines high. The motor should be turning more rapidly now. If the display trace starts as a positive going blip, change the Trigger Slope setting on the oscilloscope. If the servo is tuned correctly, the scope display should look like Figure 12 on page 26.

If the oscilloscope display looks more like Figure 13, the servo-loop needs more damping. Either turn the Damping Trimpot slightly clockwise or turn the Gain Trimpot counter-clockwise until the display most closely matches Figure 12.

Turning the Damping Trimpot up will increase rate at which the motor will "hunt" when it is stopped, increasing motor heating and audible noise when stopped. Turning the Gain Trimpot down will decrease loop "stiffness" or its ability to closely track the commanded speed. This shows up on the display as a slight waviness of the rest of the sweep after the initial blip. Either way the loop is stable.

If the oscilloscope display looks more like Figure 14, the servo-loop needs less damping. Either turn the Damping Trimpot down or turn the Gain Trimpot up until the oscilloscope display matches Figure 12.

The tuning setup is now complete. The Current Trimpot may now be adjusted to a lower level if desired. The Damping Trimpot and Gain Trimpot settings may need to be changed if the motor's load moment of inertia changes significantly.

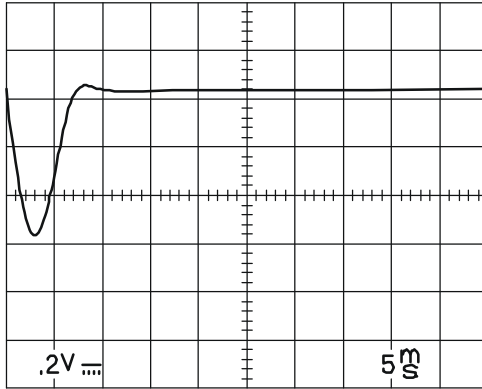

Figure 12 - optimum damping

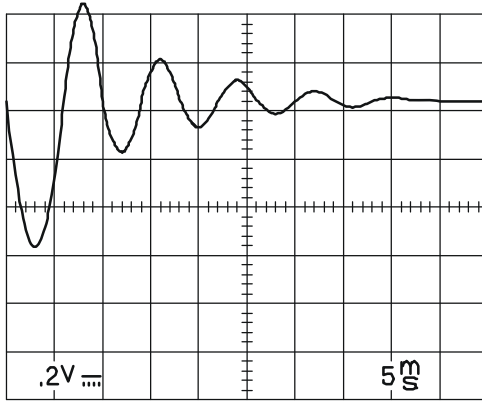

Figure 13 - under-damping

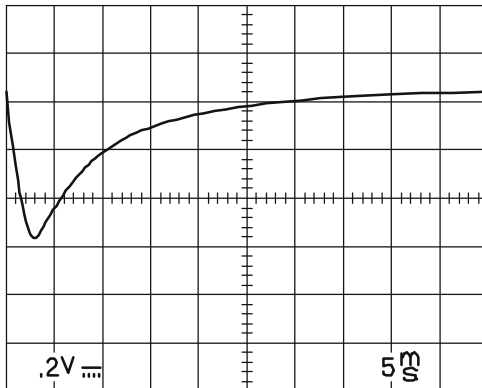

Figure 14 - over-damping

## INTERPRETING Figure 12 – Optimum Damping

Figure 12 - optimum damping, reveals considerable detail about the motor's dynamic response. In this example, a 1000-line encoder was used on a size 23 servo motor with no load attached. The power supply was 28 VDC and the Step generator frequency was 20.0 kHz for a motor speed of five revolutions per second.

By changing the direction while keeping the step rate constant, the motor is being asked to reverse instantly. This is a physical impossibility.

The motor responds by decelerating as rapidly as it can, reversing direction, and then accelerating in the new direction until it approaches the moving command position. It then decelerates until its speed and position exactly matches the moving command position in the new direction.

In this example, the time to go from five revolutions per second in one direction to five revolutions per second in the opposite direction takes just three milliseconds. At this point, the motor is 5.4 degrees behind the moving command position. In Figure 12 this is the bottom of the Position Error notch ((0.6 volt amplitude ÷ .01 volts per increment of motion) × .09° per encoder count = 5.4°).

From 3 mS to 7 mS the motor catches up to the moving command position. In Figure 12 this is the upward slope from the bottom of the notch until it crosses the 1.25 volt level.

From 7 mS to 10 mS the motor slightly overshoots (by .36 degrees) and then returns to match the moving command position. From then on the motor's speed and position matches the moving command position within .09 degrees. This outperforms a step motor by a considerable margin.

## PICKING A MOTOR

It can be a challenge to pick the right motor for an application. This process can be made easier if a few fundamentals are observed.

The first requirement is to determine how much power will be needed to drive the load. First measure or calculate the maximum torque required, in ounce-inches, and the maximum speed, in revolutions per minute (RPM), at which the motor must deliver this torque. Use Equation 2 to calculate the power in Watts necessary to accomplish this.

$$P_{WATTS} = \frac{S_{RPM} \times T_{OZ-IN}}{1351.8}$$

Equation 2

Next, select a motor voltage rating, typically 24 VDC or 48 VDC. Use Equation 3 to pick the Stall Current, in amps, of the smallest possible motor to drive this load.

$$I_{STALL} = \frac{4 \times P_{WATTS}}{V_{MOTOR}}$$

Equation 3

If the terminal resistance is preferred as a means of selecting the motor instead of the stall current, use Equation 4.

$$R_{TERMINAL} = \frac{V_{MOTOR}}{I_{STALL}}$$

Equation 4

Finally, select a motor with a no-load speed that is at least twice the maximum speed necessary to drive the load.

As an example, let's say a 24 VDC motor is to drive a load that requires 125 oz-in of torque at 1750 RPM. Using the given equations, we calculate the following:

- Power = 161.8 Watts = [(Equation 2): (1750) x (125) / 1351.8]
- Stall Current = 26.97 Amps = [(Equation 3): 4 (161.8) / 24]
- Terminal Resistance = 0.89 Ohms = [(Equation 4): 24 / 26.97]
- No-Load Speed = 3500 RPM = [2 x (1750)]

This choice works well if the peak torque (125 oz-in) is required for short time periods, such as acceleration or deceleration. While this motor is delivering 161.8 Watts to the load, it is also dissipating the same amount as heat. A motor this size would soon overheat if it were required to deliver this power continuously. The continuous torque rating of the motor must be observed, which typically will be 1/5 of the peak torque value, or 25 oz-in (125 oz-in / 5 = 25 oz-in).

## MOTOR FUNDAMENTALS:

Let's start by describing an ideal DC brush type motor and then adding what makes it a real motor. An ideal motor has zero ohms terminal resistance. Like a real motor, it has a speed proportional to the power supply voltage and will draw current from the supply proportional to the load torque. As with a real motor, output power is torque multiplied by speed and can be expressed as horsepower or watts.

An ideal motor behaves very differently than a real motor, and the difference is due to the absence of terminal resistance. As an example, let's say our ideal motor has a speed constant of 100 RPM per volt and a torque constant of 13.52 oz.-in. per amp, which are also reasonable values for a real motor. In our example a 10 VDC power supply is applied to the motor in Figure 15.

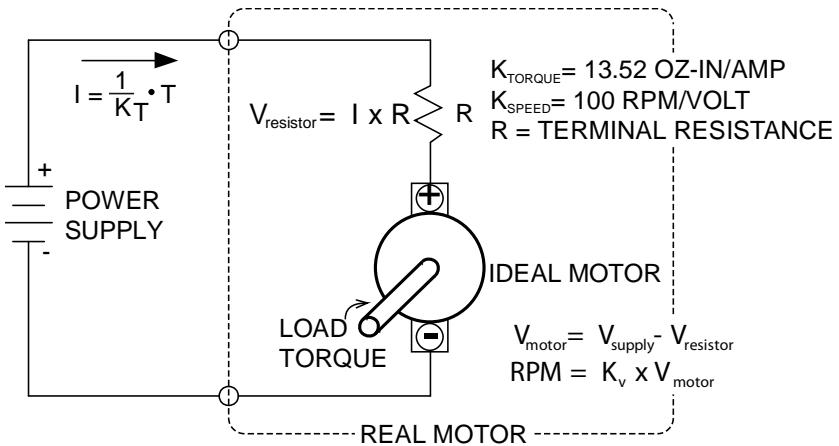

Figure 15

The ideal motor turns at 1000 RPM with a 10 VDC power supply and its speed does not change at all with load. It can drive an unlimited load, drawing unlimited current, and as long as the power supply maintains voltage, the speed will remain at 1000 RPM. The motor efficiency is 100% regardless of load simply because zero ohms dissipates no power. All electrical power going into the motor is converted to mechanical power with perfect efficiency. In short, speed is completely unrelated to torque, both are unlimited and conversion efficiency is 100%.

A real-world motor differs from an ideal motor because it has electrical resistance. In fact, a real motor can be modeled as an ideal motor in series with a resistor.

If we take our previously described ideal motor and add a 1 ohm resistor (a reasonable value) in series, it now very closely resembles a real motor. It will still draw a current proportional to torque, but now the current passes through this resistor as well. The maximum current the motor can draw is now limited by Ohm's law to 10 amps, and is called the stall current. Motor torque is also limited to the stall current times the torque constant, and is called the stall torque.

The current passing through this resistor has three consequences. The resistance develops a voltage drop across it ( $V = IR$ ), it dissipates power ( $W = I^2R$ ) and it limits the motor's power output for a given power supply voltage.

The voltage drop subtracts from the power supply voltage, leaving less voltage across the ideal motor. The motor now runs more slowly. At stall current, all the voltage is across the resistor leaving nothing for the ideal motor. Since the ideal motor's speed is proportional to voltage, by definition the motor speed at stall is zero.

The power dissipated is subtracted from the total power going into the motor, leaving the balance to be converted to mechanical power. This means efficiency becomes less than 100% at any applied load and the motor generates heat.

## CN0182 PULSE INCREMENTAL SERVO DRIVE

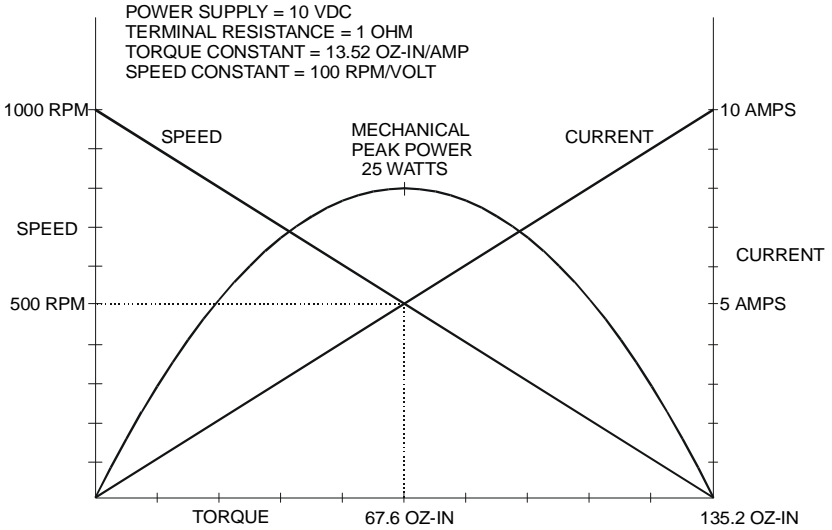

Mechanical power is the product of speed times torque. A motor running at its no-load speed is producing zero power since torque applied is zero. At the other extreme, a stalled motor is producing zero power as well, since its speed is zero. Therefore, it can be inferred that output power must increase from zero, reach a peak, and then fall back to zero again as applied torque goes from zero to stall. In fact the power versus torque curve is parabolic and peaks at  $\frac{1}{2}$  of stall torque (Figure 16).

Motor efficiency is the percentage of electrical power delivered to the motor that is converted to mechanical power; the rest is dissipated as heat. As seen above, the motor delivers maximum output power at one half of its stall current. At this point the series resistor has half of the power supply voltage across it, leaving the other half for the ideal motor. Since the same current flows through both, half the power is converted to heat. This means the real motor efficiency cannot be more than 50% at peak power output.

If there were no friction in the motor, efficiency would be 100% for an infinitesimal torque load, decreasing linearly with load to 0% at stall torque.

The continuous rated torque is typically one tenth of the motor's stall torque. Because motor heating goes up with the square of the current ( $W = I^2 R$ ), peak heat dissipation in a typical motor is 100 times higher than what the motor can dissipate continuously. Heat dissipation at peak motor power output is 25 times the motor's continuous dissipation. Be careful what percentage of time the motor must operate above its continuous rated torque!

## SPECIFICATIONS

	MIN	MAX	UNITS
<b>ELECTRICAL</b>			
Supply Voltage	18	80	VOLT (DC)
Current (continuous)	--	20	AMP
Step Pulse Frequency	0	1	MHz
Opto-isolator current	10	10	mA
<b>Encoder</b>			
Frequency	0	200	kHz
Servo Lock Range	-128	+128	COUNTS
Signal Level			
TTL encoder	0	5	VOLT (DC)
analog encoder	-1	+1	VOLT (DC)
Supply Current			
+5 Volt Supply	--	100	mA
-5 Volt Supply	--	50	mA
<b>ENVIRONMENTAL</b>			
Operating temperature	-20	75	°C
	-4	167	°F
Humidity	0	100	%
Shock	--	100	G
<b>MECHANICAL</b>			
Weight	17	19	ounce
	482	539	gram
Terminal Screw Torque		4.5	lb/in
Size (LxWxH)	4.75 x 4.00 x 0.85		inch
	121 x 102 x 22		millimeter
Mounting hole centers	3.625 x 3.625		inch
	92 x 92		millimeter
Mounting screw size	6	8	#

CN0182 PULSE INCREMENTAL SERVO DRIVE

FULL SCALE DRAWING

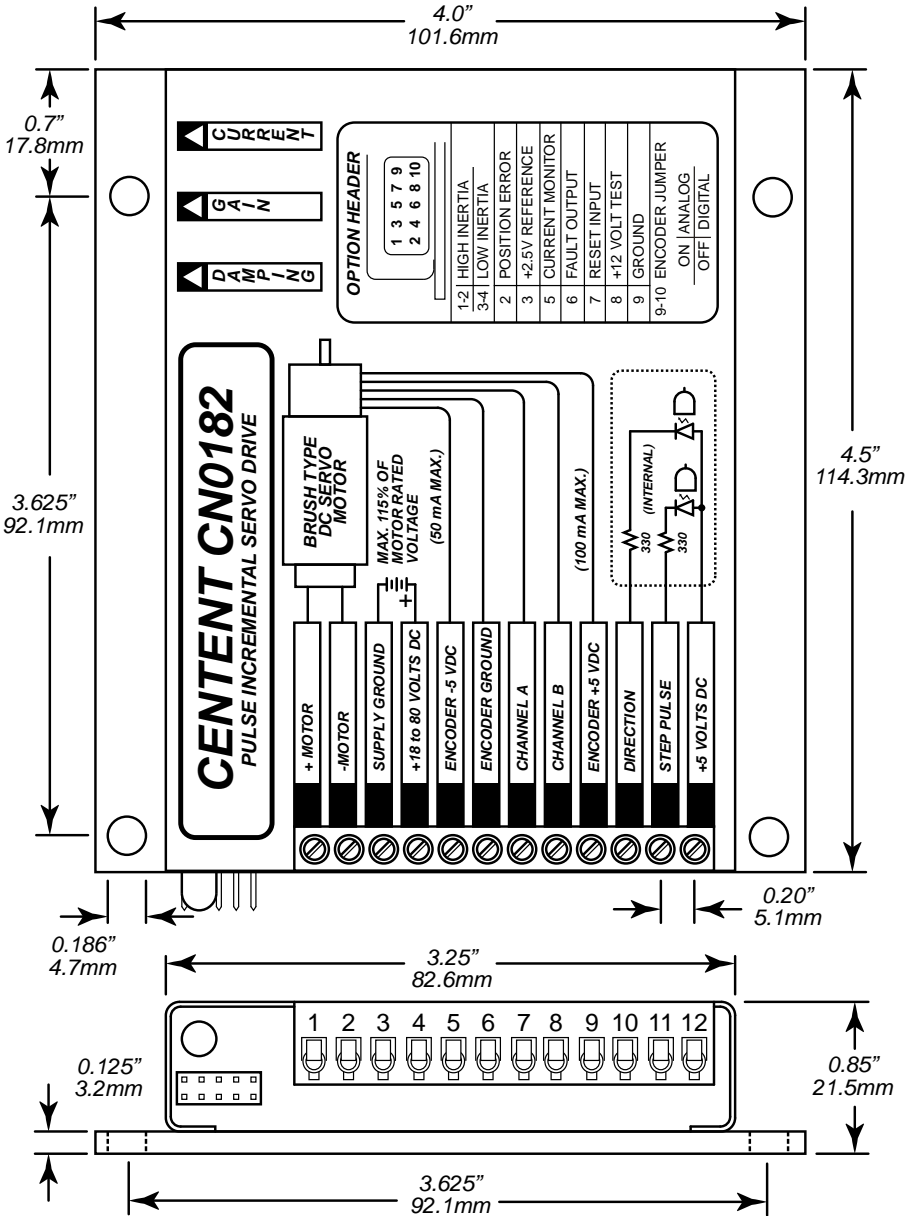

Figure 17